

Hardware projects and printed circuit boards

Generally, when doing a hardware project, you will need a printed circuit board (PCB) prototype to give to the client.

Learning to do PCBs is not hard — you can definitely learn the basics on your own. There is a class – EE 333 – that includes learning about PCB technology and design techniques.

The circuit design process:

1. Come up with an initial design for the circuit. Calculate and simulate until the paper design meets the specifications.
2. Choose the specific parts that will be used. Component footprint (physical size) is as important as the circuit parameters.
3. Test the design by building breadboard prototype.
4. Do a second prototype soldered together on a perf-board.
5. Design the PCB and have it manufactured.
6. Build the circuit on the PCB and test it.
7. Repeat any steps as needed to fine-tune circuit performance.

Printed circuits boards (PCBs)

A PCB provides a substrate that simultaneously serves as a structural mount for the various components (chips, resistors, capacitors, sensors, switches, connectors, etc), insulation between isolated components, and copper wiring to connect the components into a circuit. Since all of the electrical connections are contained in the PCB, building a circuit is a simply matter of soldering the components into place.

The advantages:

- Repeatability
- Reliability
- Lower cost (automated manufacturing)
- Reduced size
- Faster circuit speeds (probably)
- Better heat handling (probably)

The old days – Point-to-point soldering

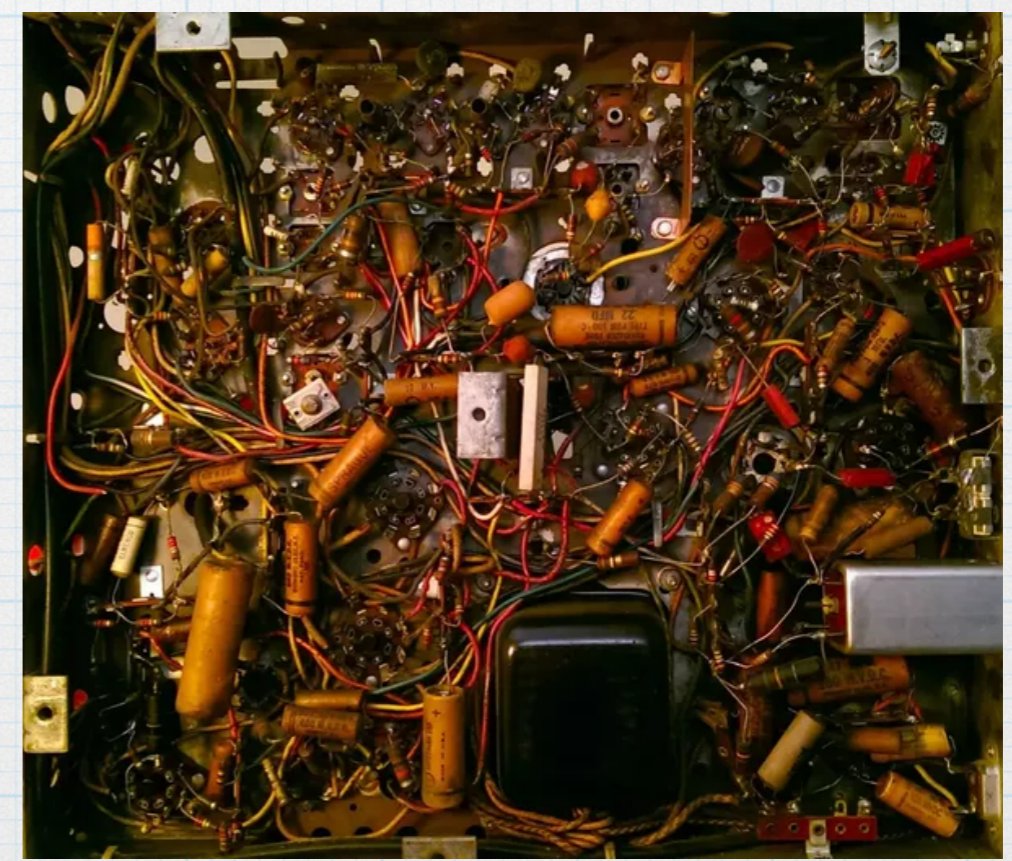
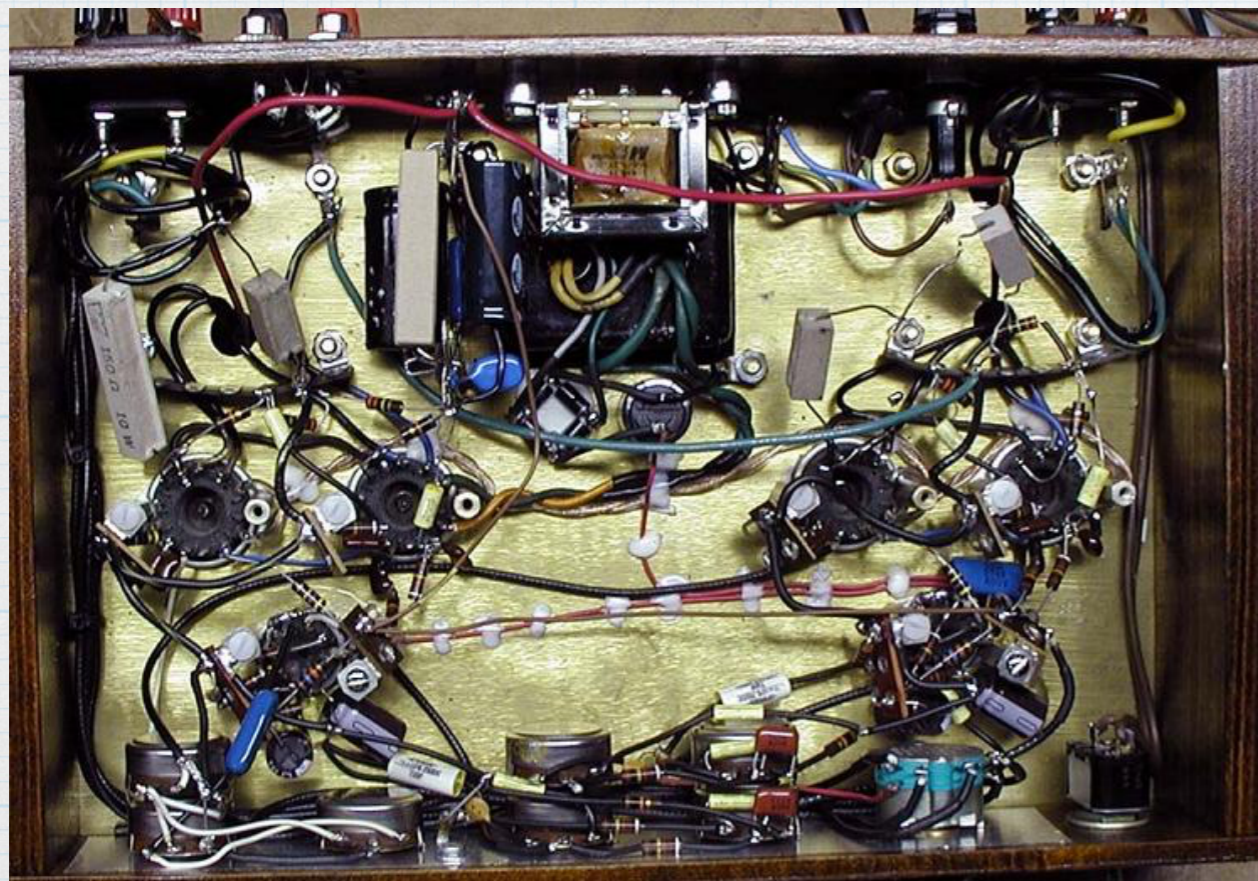
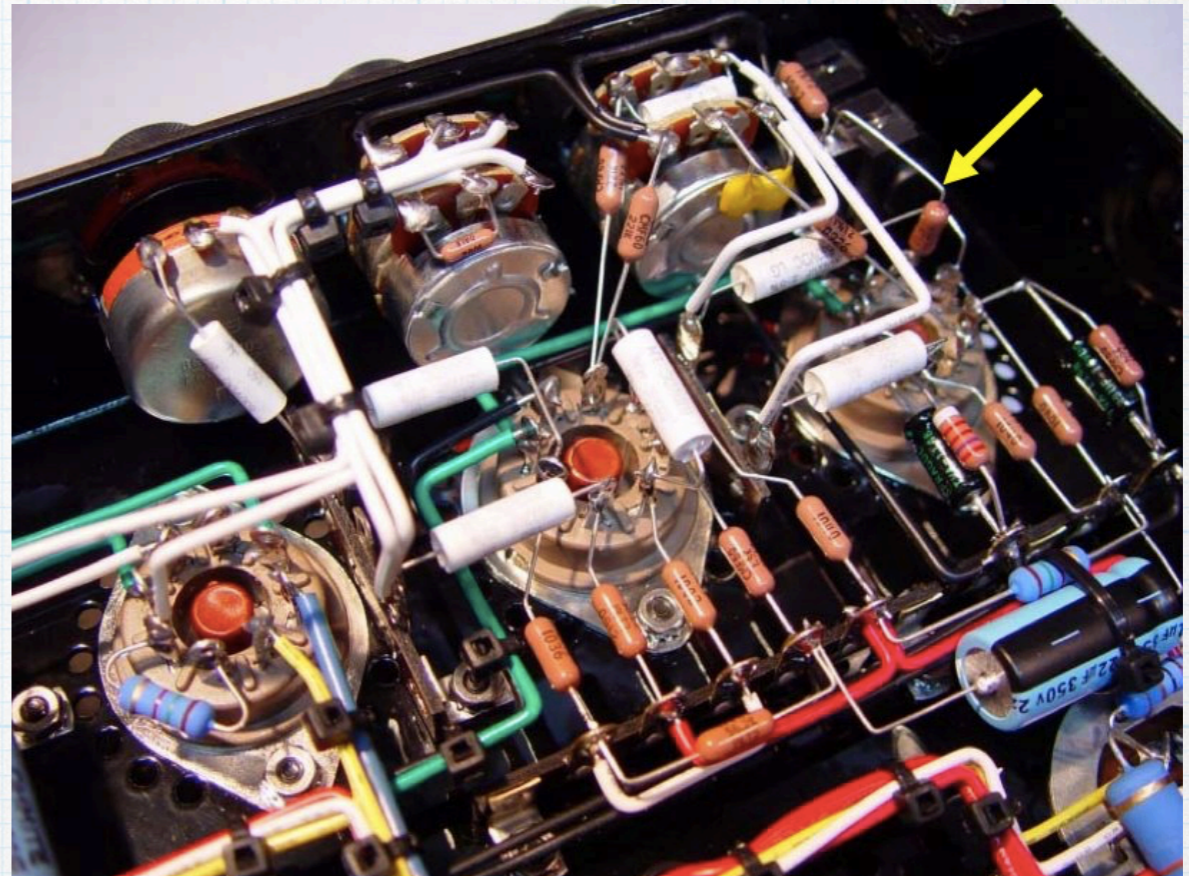
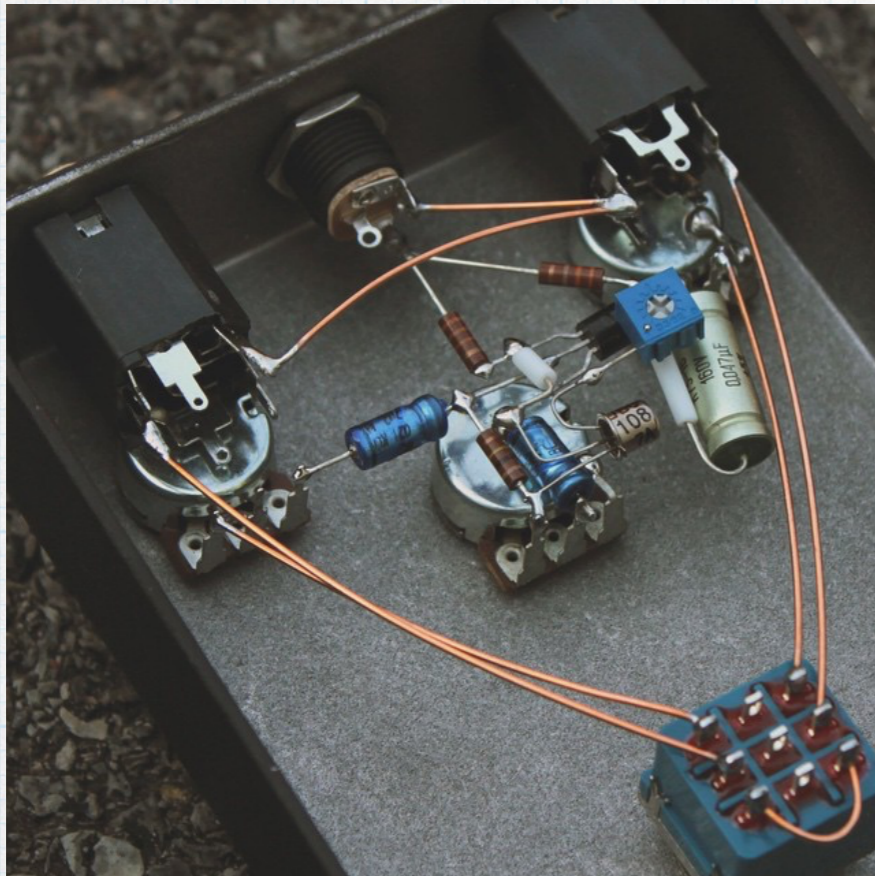

Wire wrap – no solder required, but what a tangle

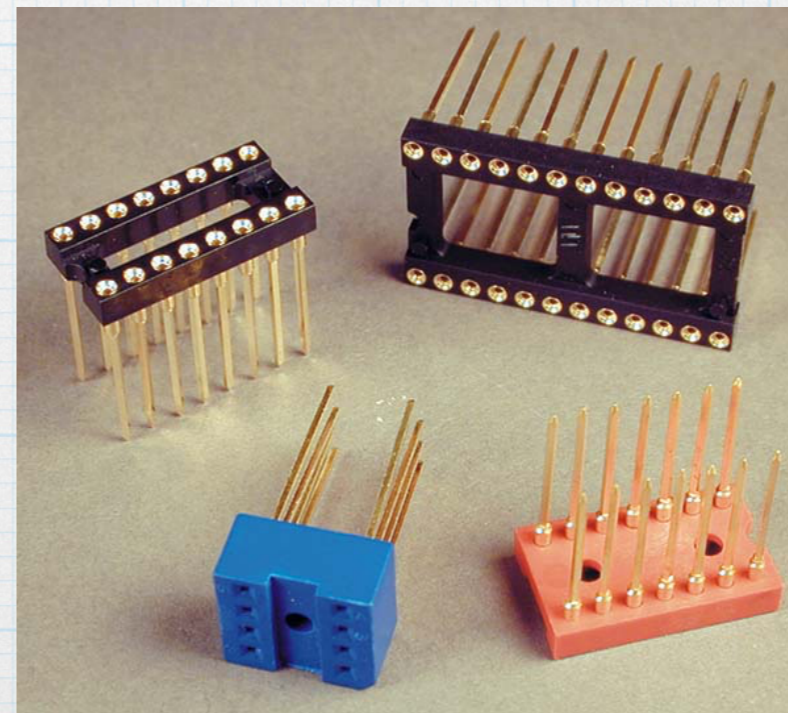
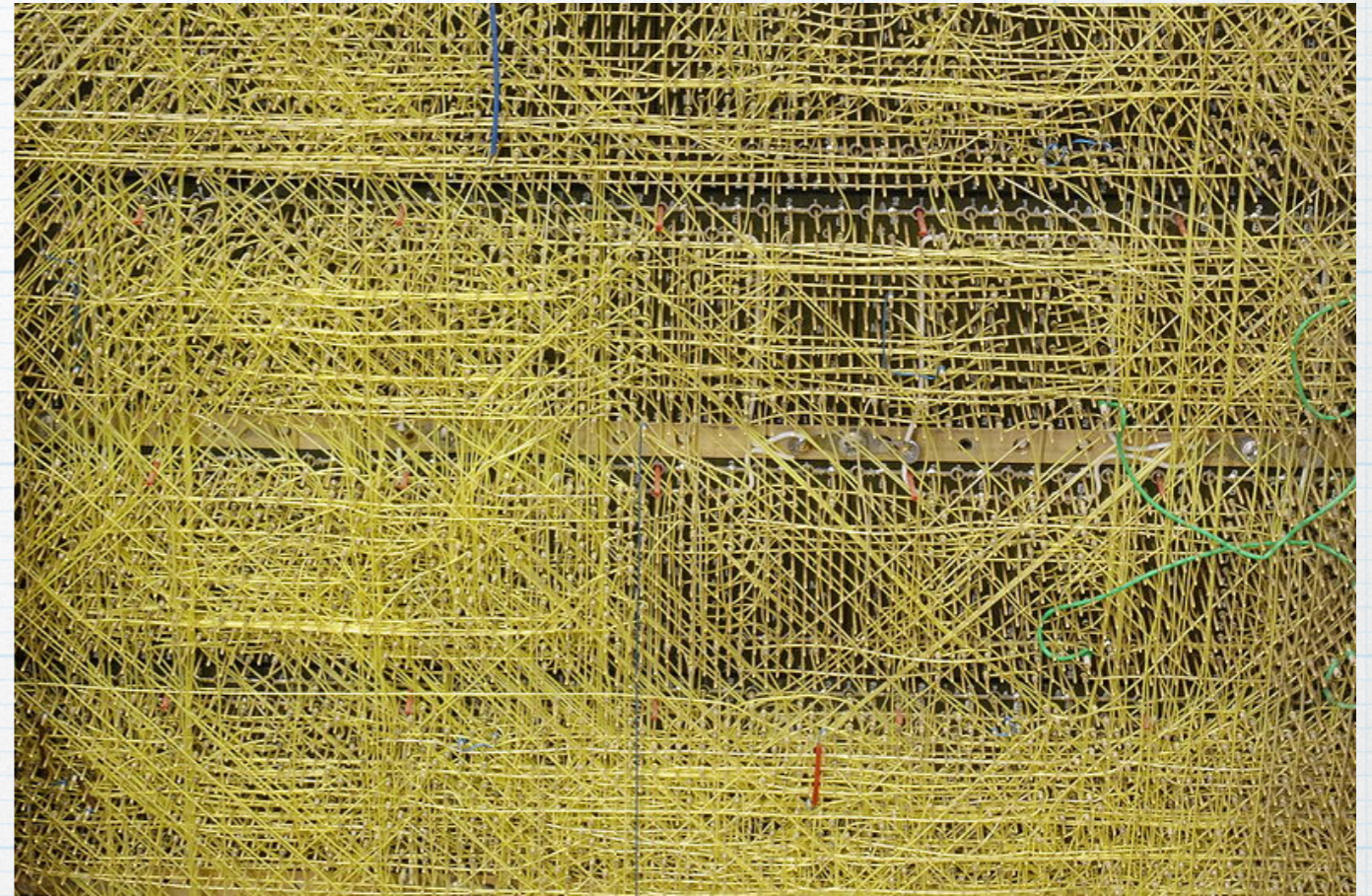
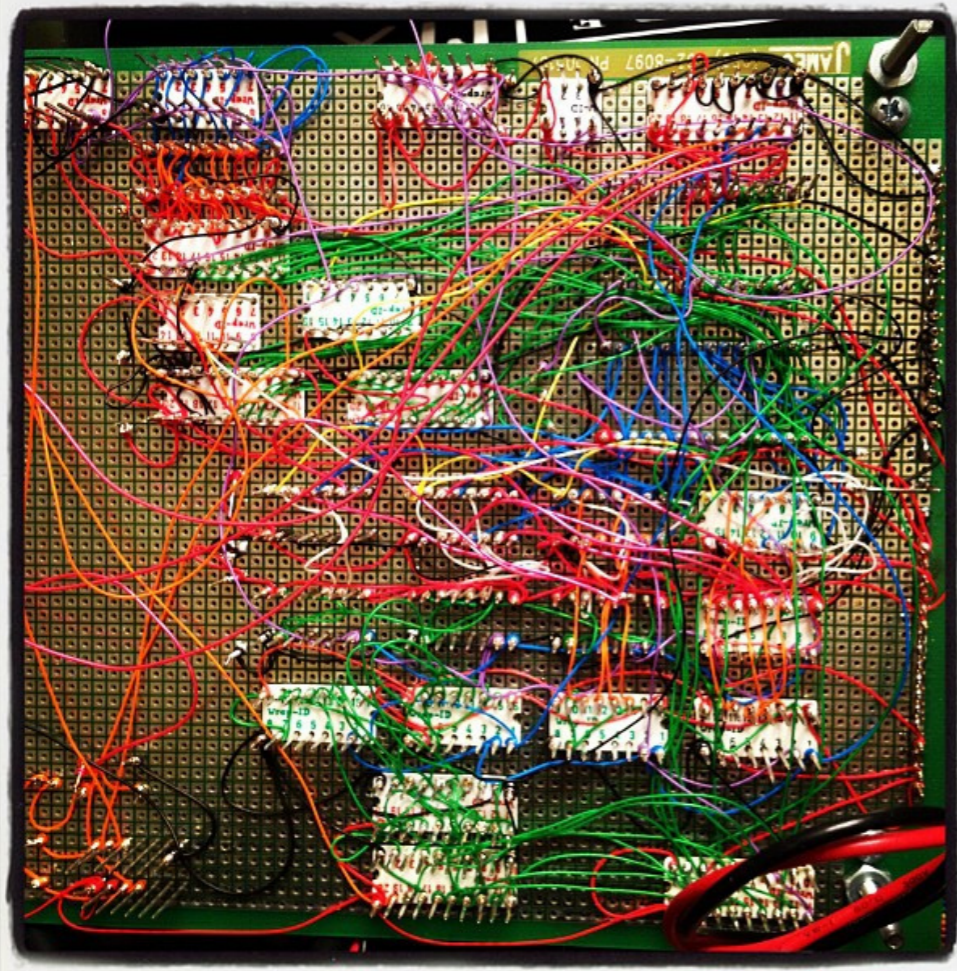

Printed circuit boards (examples from EE 333)

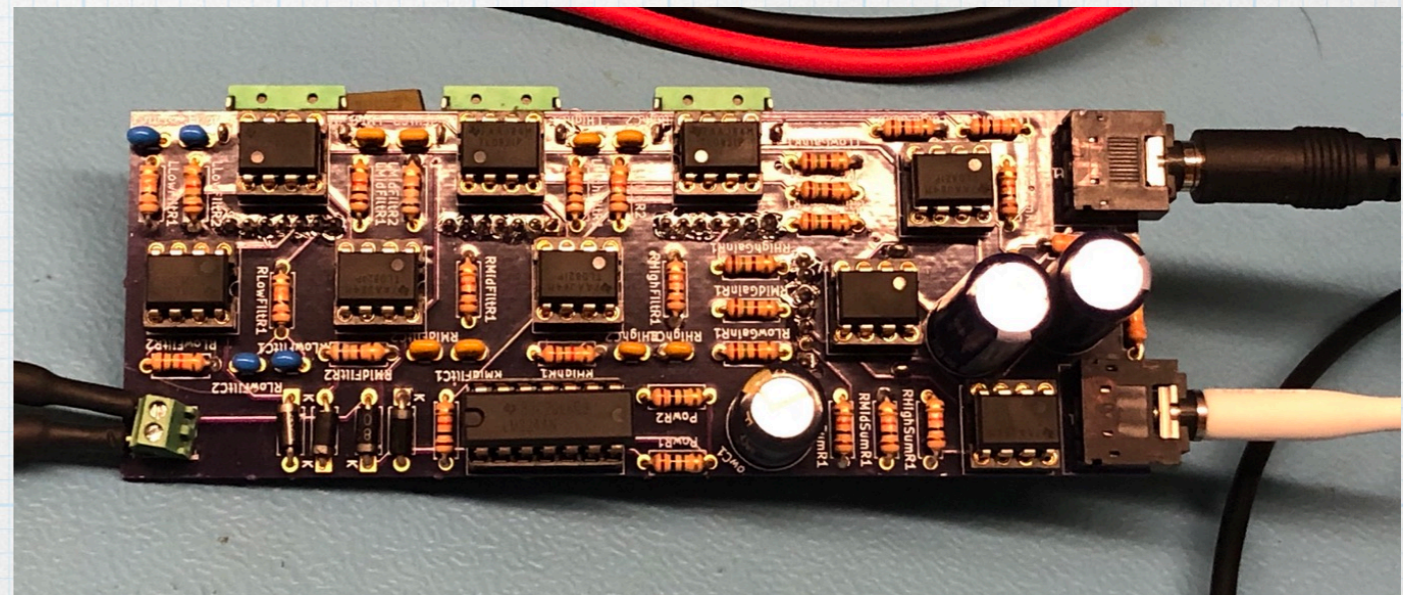
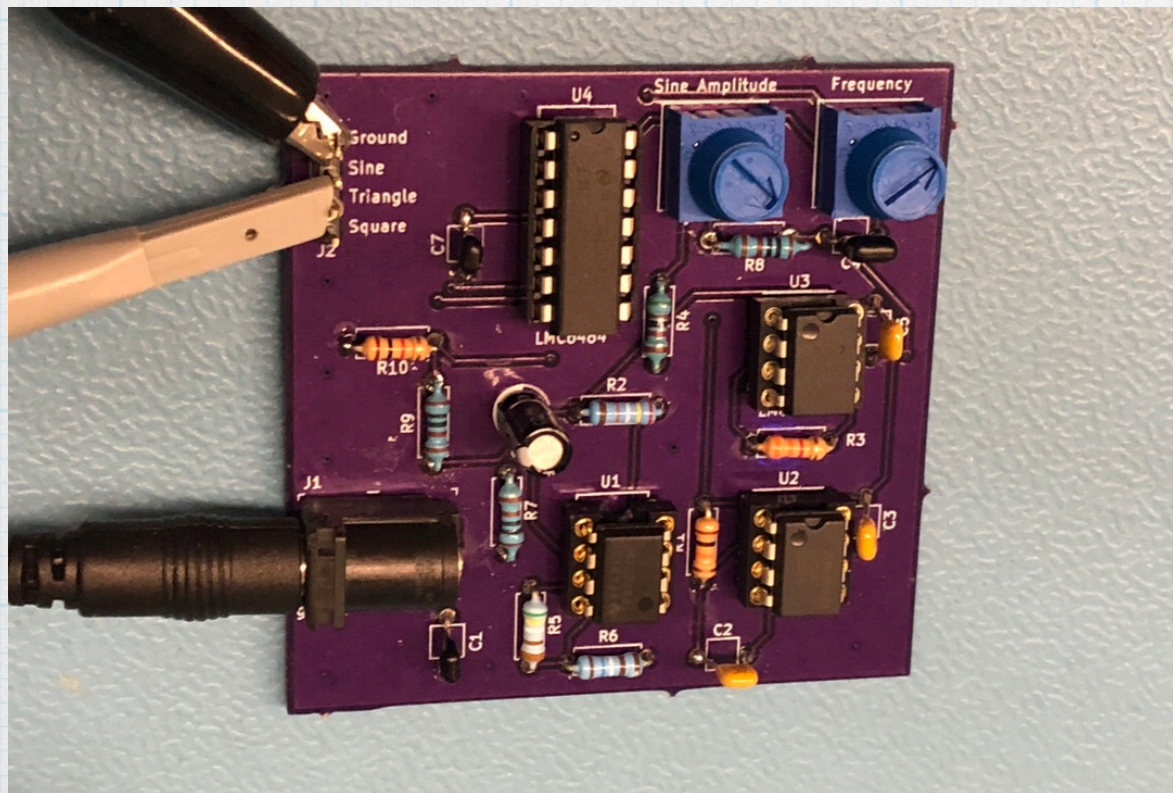
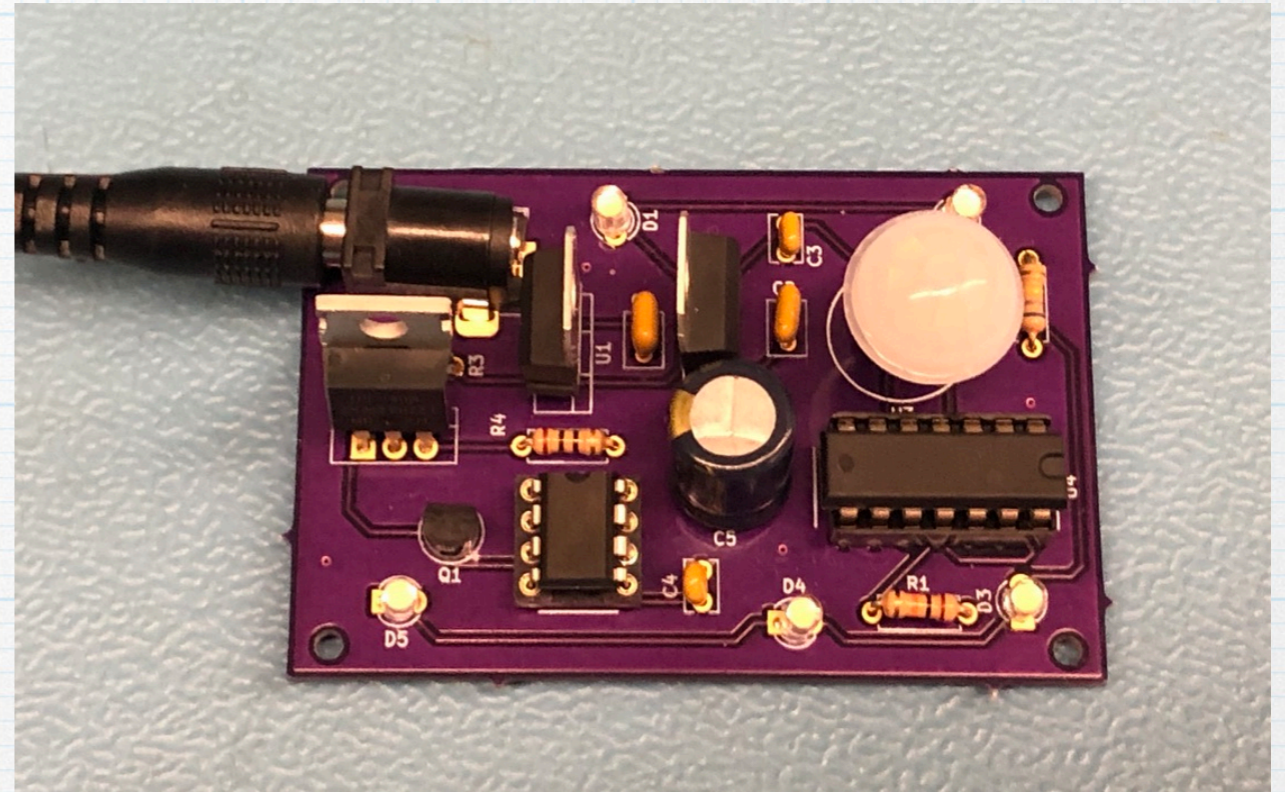
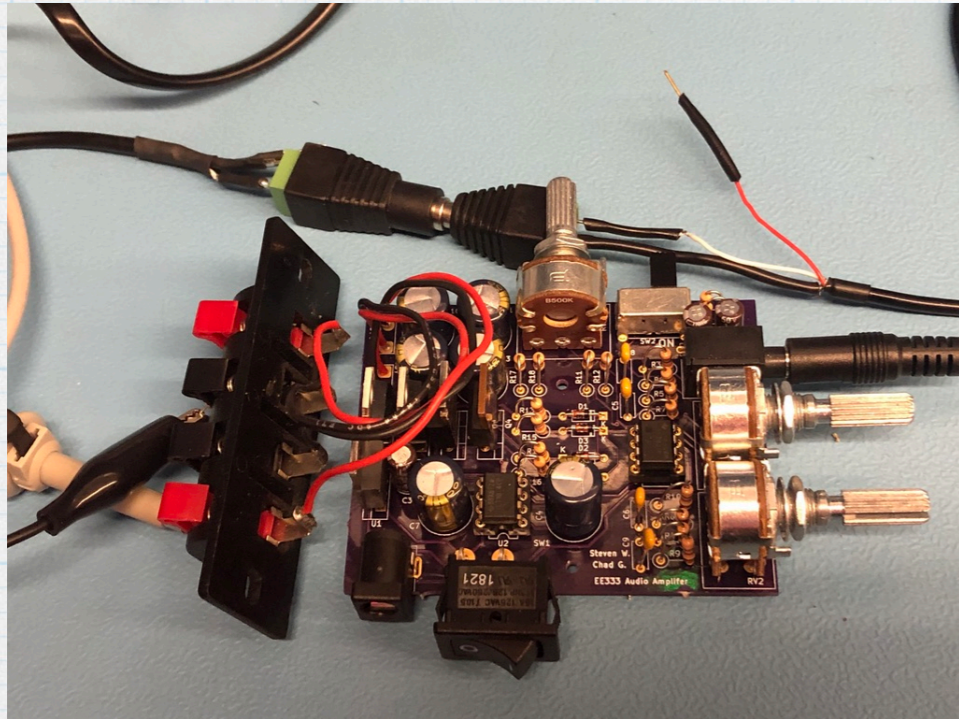

A comment about units

The International System of Units (SI units or more generally metric units) are standard in most scientific and engineering situations.

However, in the PCB business, measurements of physical length may use Imperial units — board sizes, component dimensions, component thicknesses, trace dimensions, and separation between pins might be given in terms of inches and mils. When defining the features of a PCB, it is essential to know which units are being used. In the U.S., imperial units are quite common. In Europe and the rest of the world, millimeters are standard. Some important conversions.

- 1 inch = 25.4 millimeters.
- 0.1 inch = 2.54 mm (standard pitch for through-hole components)
- 1 inch = 1000 mils (1 mil = 1/1000 of an inch.)
- 1 mil = 0.0254 millimeter = 25.4 micrometers.

PCB structure - insulator

The basic insulating substrate is made using “FR-4”, which is an industry standard glass-reinforced epoxy laminate (fiberglass). FR-4 is a particular *flame retardant* composition that is the most widely used PCB material.

- FR-4 is mechanically rigid with a good strength-to-weight ratio, so that it serves as a solid substrate for holding the circuit components. It is easy to cut and drill holes without compromising the structural integrity.
- It is a good insulator. (Resistivity $\approx 10^{13} \Omega\cdot\text{cm}$. Dielectric constant ≈ 4.4 .)
- It is stable in a variety of atmospheric conditions — it does not absorb water easily.)
- It can be made in a variety of thicknesses. The most common thickness for PCBs is 0.0625 in (1/16 inch), but thinner and thicker boards are possible, including extremely thin layers for flexible PCBs.



PCB structure - copper

To make the PCB starting structure, the FR-4 insulator is laminated with layers of copper, top and bottom. These layers are sometimes referred to as the copper cladding. Sometimes there is on copper on only one side.

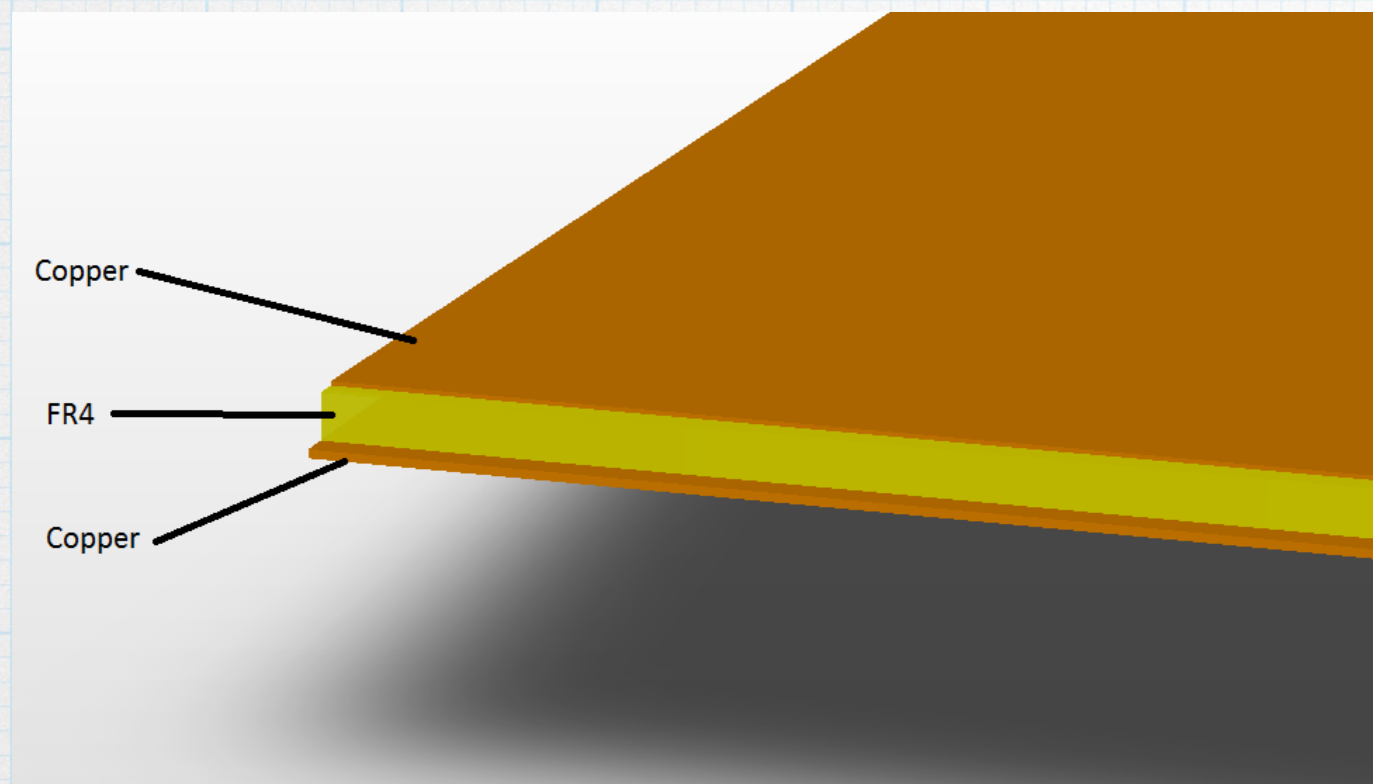

The thickness of a typical copper layer is “1 ounce”. (Wait...what?) This number corresponds to the the weight of copper in one square foot of the layer — 1 oz/ft². (Yes, strange units. In SI, it would be 0.315 kg/m², but this is value is almost never used.) Using the density of copper (8.96 grams/cm³) and working backwards, we find that 1 oz. of copper corresponds to a thickness of 1.344 mils = 0.034 mm (or 34 microns). Copper layers of 0.5-oz. (0.672 mil) and 2-oz. (2.688 mil) are also common.

PCB structure - traces

The copper/FR-4/copper sandwich is the starting point for making the PCB. The components will be attached to the copper surfaces — in principle they can be on either side. The connections between the pins of the components are made by making patterns — traces — in the copper between the connected pins. The traces are made by removing the unwanted copper. This is known as a “subtractive process” and is very similar to how patterns are made in an integrated circuit. The pattern of copper traces define the circuit. Note that the traces are defined *before* the component are put in place.

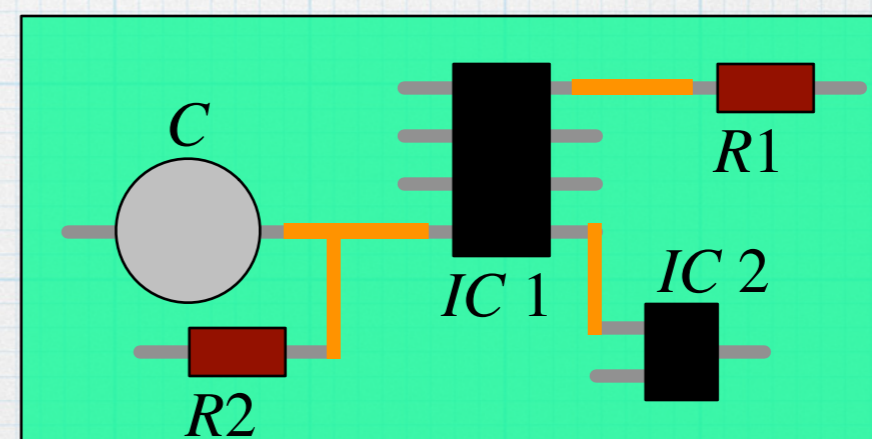
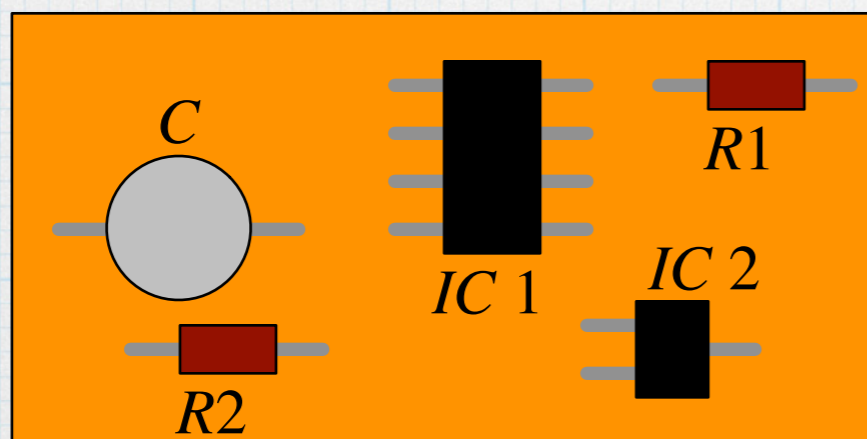

Trace resistance

In the idealized world of EE 201, wires were “perfect”, having no resistance or inductance. This made calculations simple. In real PCBs, we must deal with the fact that copper is not ideal. Copper is a very good conductor, but the resistivity is not zero, and every copper trace has some non-zero resistance. The traces must be sized to assure that the trace resistances do not affect the operation of the circuit. This is a particular concern with traces that carry high currents, like output connections, power supply leads, and ground connections.

Resistors carrying current heat up. A trace that has significant resistance and lots of current can become very hot. This can be a real problem, particularly if the trace is “buried” in an internal layer of a PCB. A hot trace can burn out, ruining the circuit, or worse, it might start a fire.

PCB traces can be treated as simple rectangular resistors. Using the classic resistor formula:

$$R = \frac{\rho L}{A} = \frac{\rho L}{W \cdot t}$$

The resistivity of copper is $1.7 \times 10^{-6} \Omega \cdot \text{cm}$, and 1-oz copper has $t = 0.0034 \text{ cm}$. A trace with $W = 10 \text{ mils}$ and $L = 1 \text{ inch}$ would have a resistance of about $50 \text{ m}\Omega$ — seemingly small. But if the current flowing through the trace is 1 A , there is a 50 mV drop and it will dissipate 50 mW of power — these numbers might be significant.

PCB traces can be treated as simple rectangular resistors. Using the classic resistor formula:

$$R = \frac{\rho L}{A} = \frac{\rho L}{W \cdot t}$$

The resistivity of copper is $1.7 \times 10^{-6} \Omega \cdot \text{cm}$, and 1-oz copper has $t = 0.0034 \text{ cm}$. A trace with $W = 10 \text{ mils}$ and $L = 1 \text{ in}$ would have a resistance of about $50 \text{ m}\Omega$ — seemingly small. But if the current flowing through the trace is 1 A , there is a 50 mV drop and it will dissipate 50 mW of power — these numbers might be significant.

Through holes (vias)

There are two reasons why it is necessary to have some holes through the PCB. The first is to provide mounting holes for “through-hole” components. (More on these shortly.) The other is provide electrical connection between top and bottom copper traces.

The holes are drilled using the standard technique using a spinning mechanical drill bit. Through holes diameter above some minimum specified by the manufacturer. (10 mil = 0.01 inch in the case of OshPark.) If the via is meant to hold a component lead, it is obvious that the via diameter must be bigger than the thickness of the lead wire.

Most vias will be “plated”, meaning the sidewalls of the holes will be covered with metal, forming a connection from top copper to bottom copper. Plated through holes are also easier to solder.

Through holes (vias)



Plated through hole.

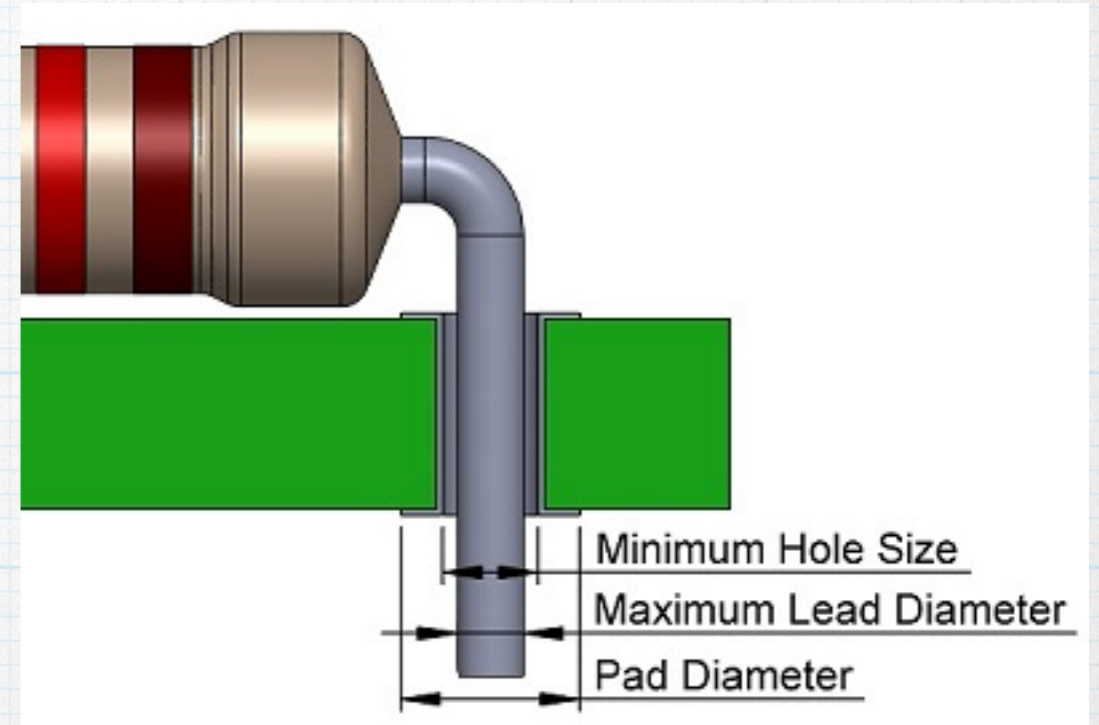

Make sure the hole is big enough for the lead wire on the component.

Two types of packages

Through-hole:

Every lead of every component fits into a hole in the PCB and is soldered into place.

- Older tech.
- Not as compact. The packages are large.
- Relatively easy to assemble by hand or by machine.
- Re-work is easier.
- Probably a good choice for initial prototyping.

Note the use of sockets in the lower photo.

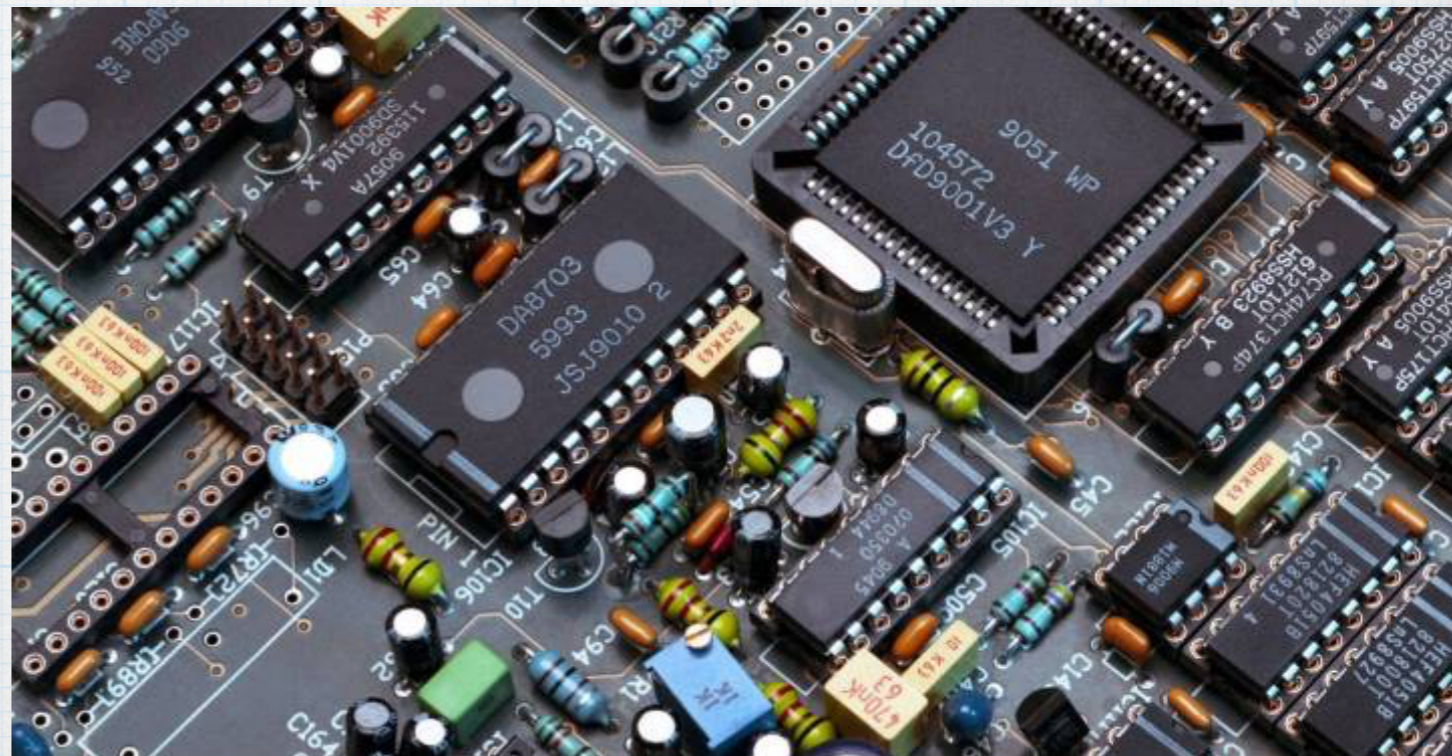
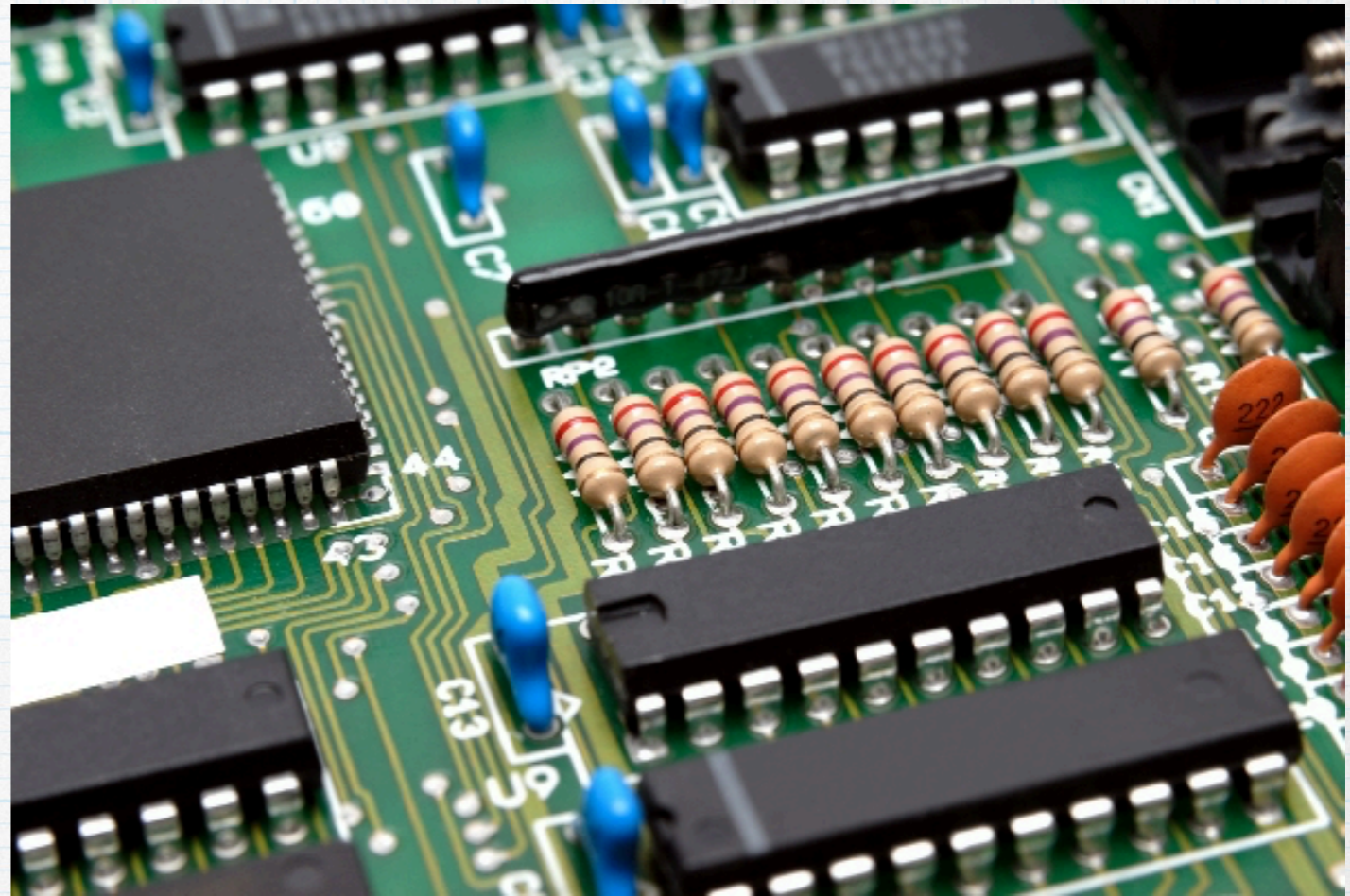

Two types of PCBs

Surface-mount:

Component leads are soldered to pads on one side of the PCB.

- Newer tech.
- Much more compact.
- Components are easily mounted on both sides of the PCB.
- Holes are still used for top-to-bottom interconnect.
- Harder to hand-assemble. More suited for automated assembly.
- Probably better as a second prototype.

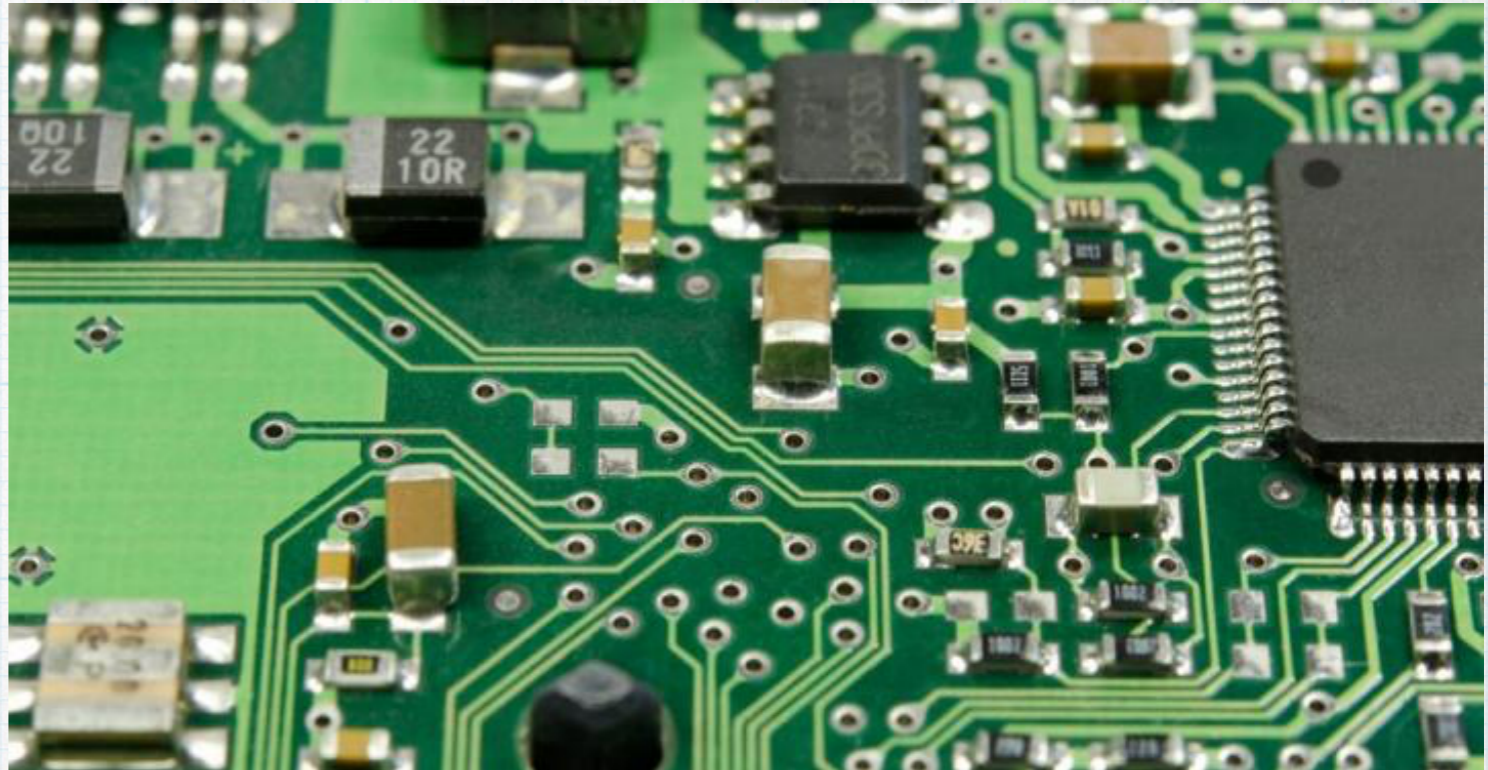

PCBs with mixed through-hole and surface-mount components are very common.

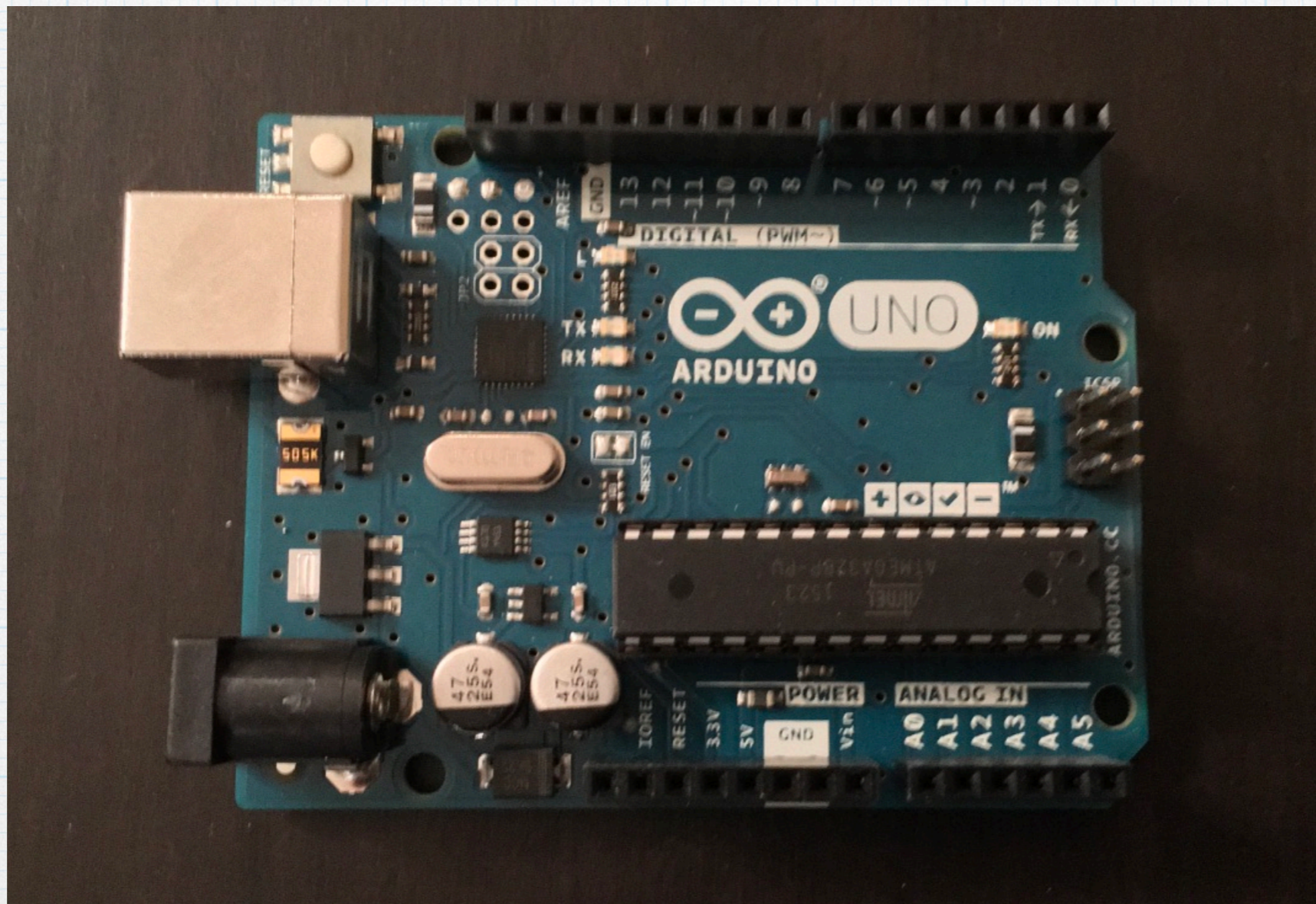

Many older components are available in both through-hole and surface-mount versions. Newer designs often come only in surface-mount, meaning that hand prototyping is more difficult.

Surface-mount vs. through-hole

1. Through-hole chips all have their leads spaced to conform to a 0.1" x 0.1" grid. Easy to lay out.
2. Holes for resistors, capacitors, inductors, etc. can be placed wherever needed.
3. Through-hole parts are easy to solder – and unsolder.
4. Surface mount parts are significantly smaller. (Not constrained to the 0.1" x 0.1" grid.)
5. Resistors and capacitors have standard sizes. Most other components also are standardized.
6. SM chip lead patterns are standardized. (Mostly.)
7. Soldering for surface mount parts is much harder. (Sometimes impossible to do by hand.)
8. Some newer parts are *only* available in SM packages.

Advice: If possible, senior design projects should stick to through-hole parts and PCBs.

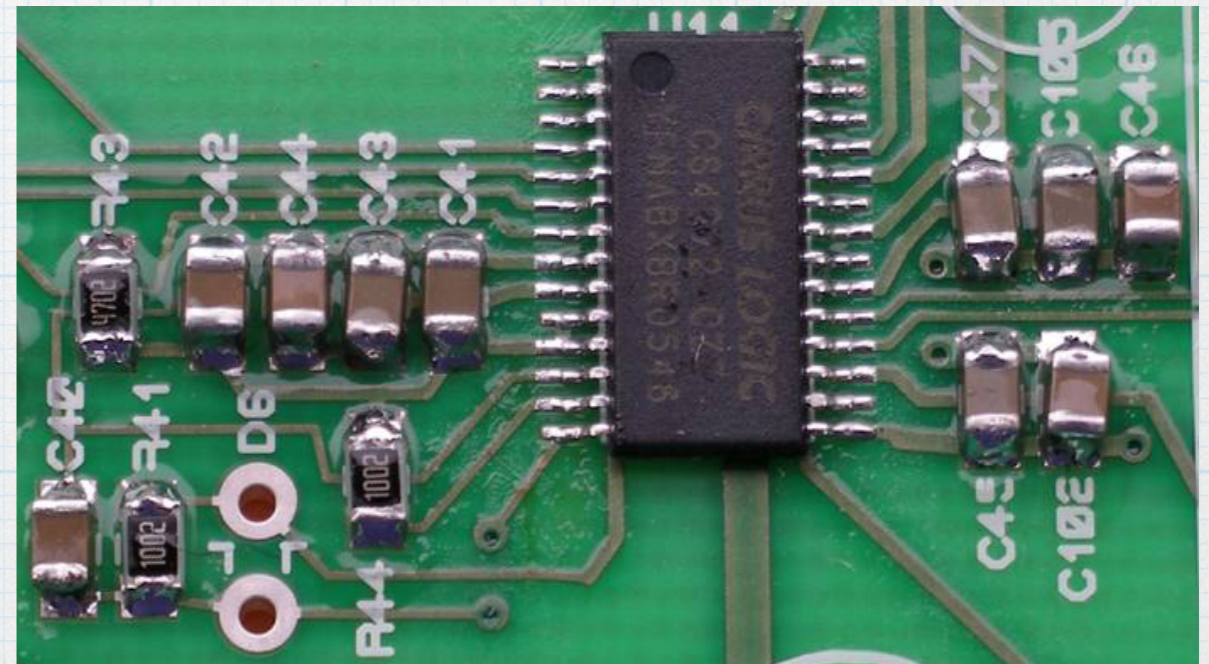
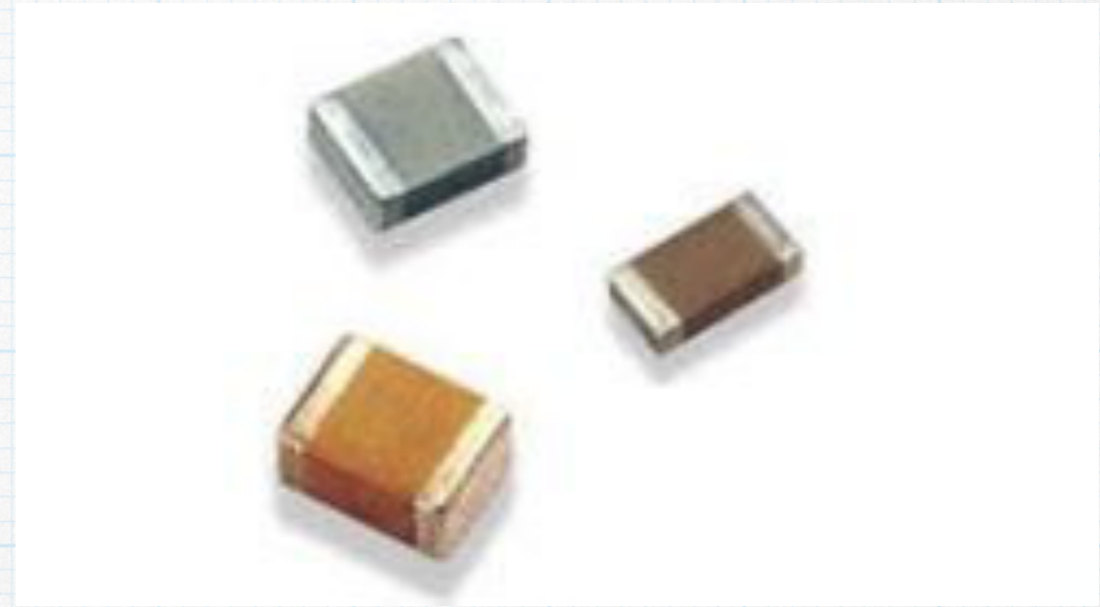
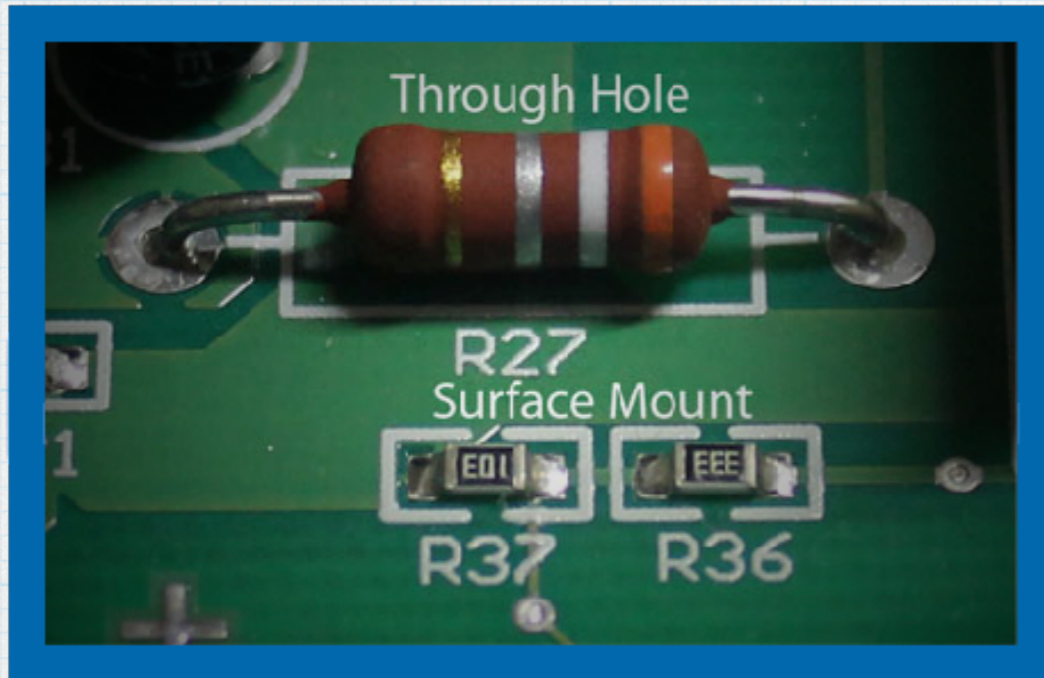

Standard surface-mount sizes for resistors & capacitors

Imperial	Dimension (L x W) in mils	Metric	Dimensions (L x W in mms)
1005	15.7 x 7.9	0402	0.4 x 0.2
0201	24 x 12	0603	0.6 x 0.3
0402	39 x 20	1005	1.0 x 0.5
0603	63 x 31	1608	1.6 x 0.8
0805	79 x 49	2012	2.0 x 1.25
1008	98 x 79	2520	2.5 x 2.0
1206	126 x 63	3216	3.2 x 1.6
1210	126 x 98	3225	3.2 x 2.5
1806	177 x 63	4516	4.5 x 1.6
1812	180 x 130	4532	4.5 x 3.2
1825	180 x 250	4564	4.5 x 6.4
2010	197 x 98	5025	5.0 x 2.5
2512	250 x 130	6332	6.3 x 3.2
2920	290 x 200	7451	7.4 x 5.1

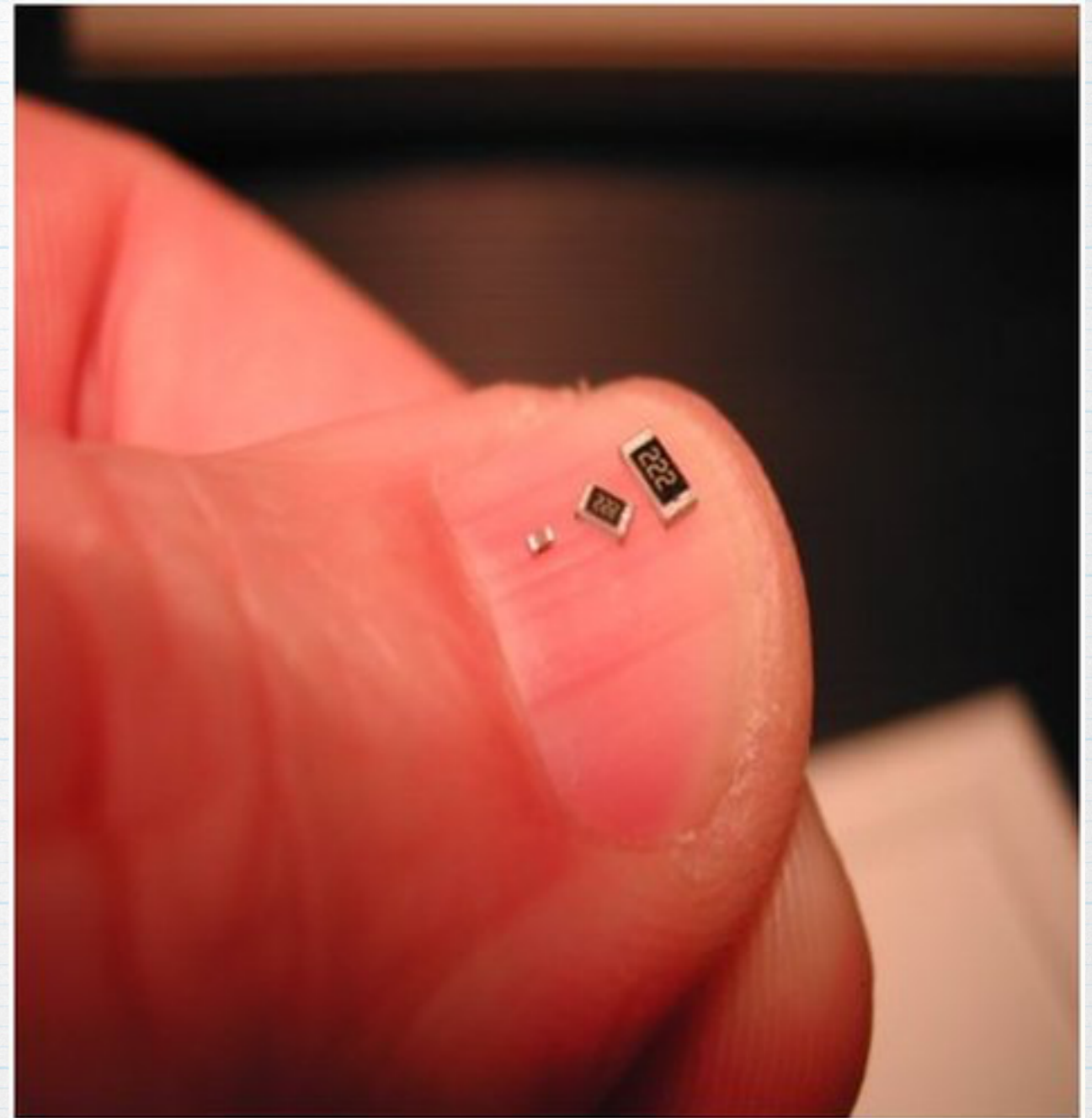
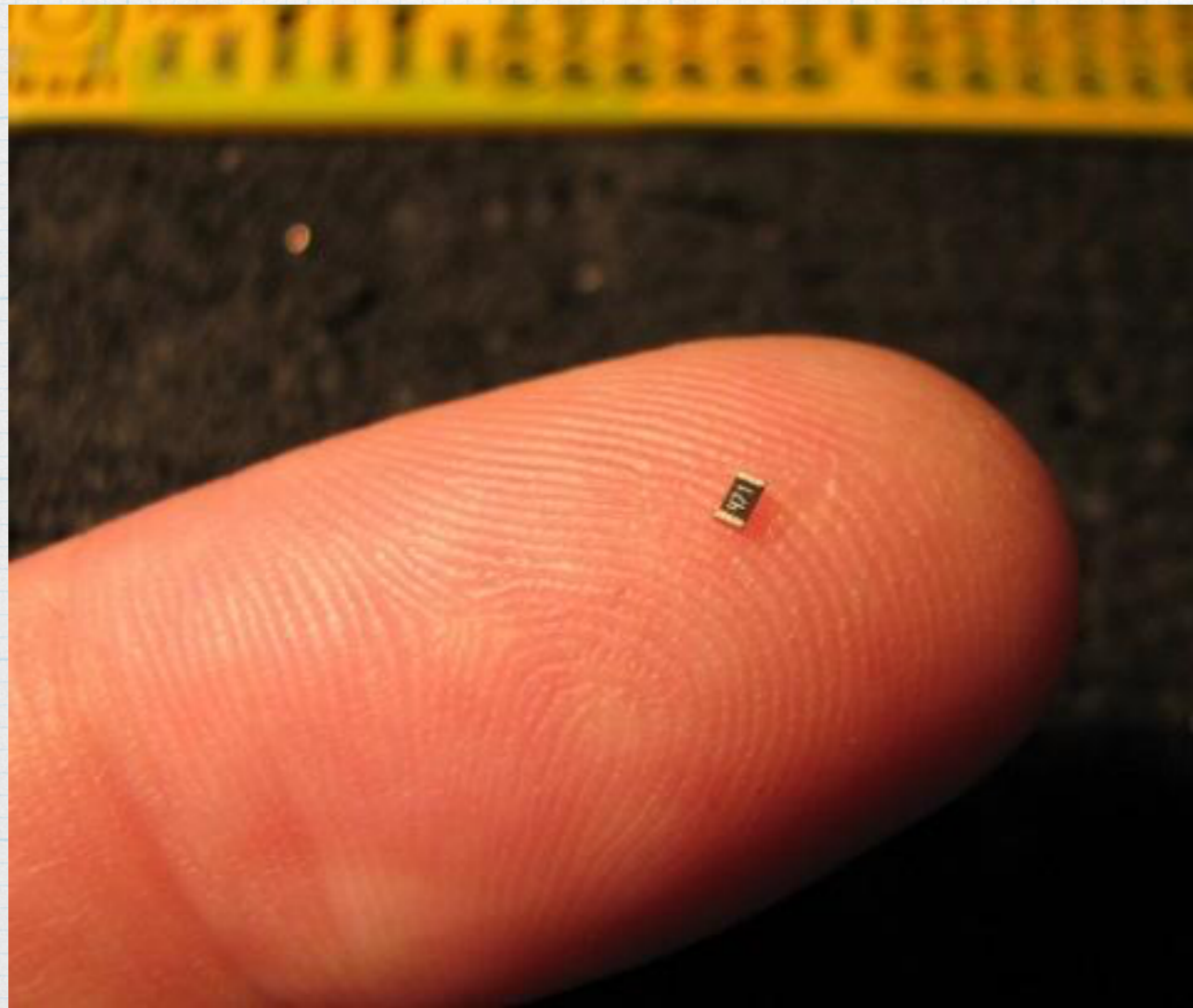

Surface mount chip packages

Chip packages are also more compact with pin spacings (pitch) that can be much smaller than the 100 mil (2.54 mm) spacing of through-hole parts.

Small-outline integrated circuit (SOIC) – dual, in-line, 8 or more pins with spacing of 50 mils (1.27 mm).



Variants are Shrink Small-Outline Package (SSOP), Thin Small-Outline Package (TSOP), Thin Shrink Small-Outline Package (TTSOP), Quarter-size Small-Outline Package (QSOP), Very Small-Outline Package (VSOP), all of which offer smaller, thinner packages with smaller lead spacing — down to 25 mils (0.65 mm) or even less.

Surface mount chip packages

The leads can also be arranged around all four sides of the chip package.

Quad Flat Package (QFP) – Square package with leads on all four sides. Pin count ranges from 32 to 304 (and bigger) with lead spacing ranging from 0.4 mm to 1 mm.

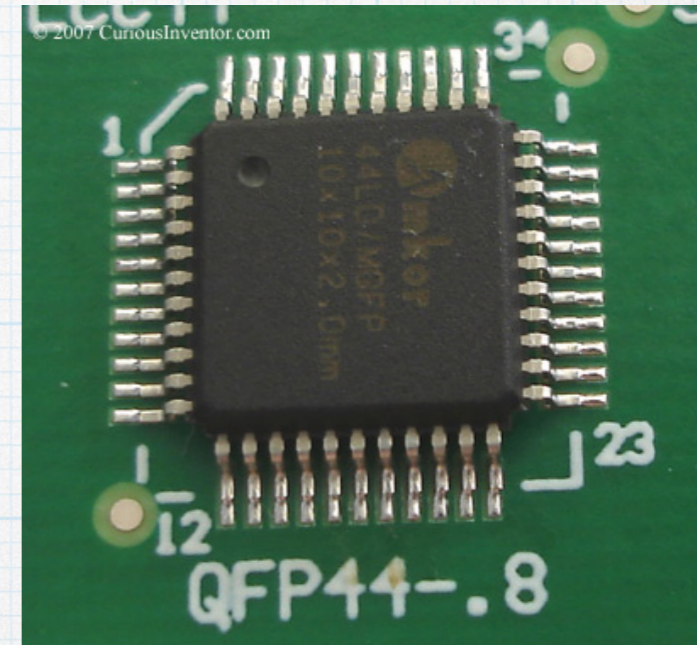

Variants are Plastic-Lead Chip Carrier (PLCC), Low-Profile Quad Flat Package (LQFP), Plastic Quad Flat Package (PQFP), Ceramic Quad Flat Package (CQFP), Thin Quad Flat Package (TQFP).

Surface mount chip packages

There are packages that are made even smaller by getting rid of the pins that are sticking out or by arraying the contacts completely underneath the package. These are (almost) impossible to solder by conventional means.

Quad Flat No-lead (QFN) – Like a QFP with with no pins extruding from the sides

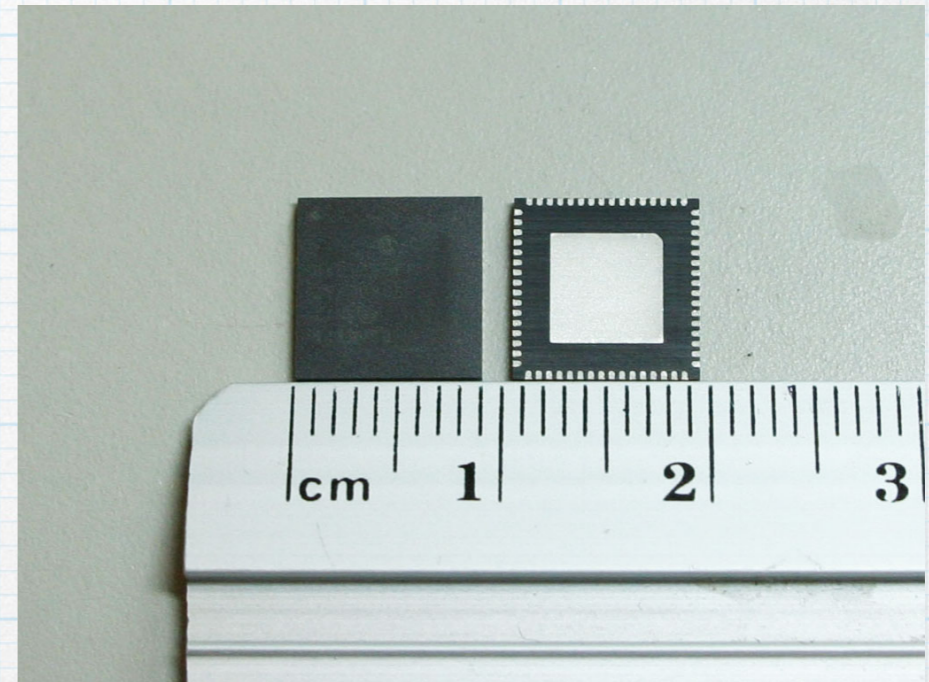

Grid arrays — Ball Grid Array (BGA) and Pin Grid Array (PGA)

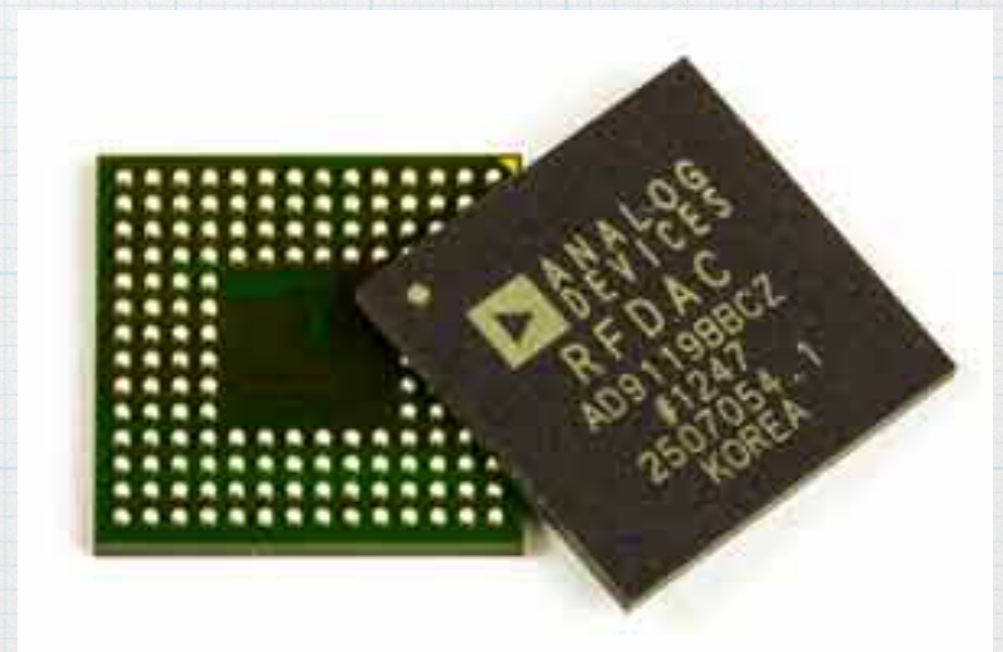

Other parts of the PCB

In addition to defining the traces and vias, there are a couple of other aspects that are important to PCB:

1. **Solder mask** (or solder resist) — Essentially a layer of plastic that covers everything *except* for the areas where solder will go. Since solder works by wetting and flowing over metal surfaces, the solder mask works by preventing wetting in those regions where we don't want solder. Also, the solder mask gives the PCB its color.
2. **Silkscreen** — Lettering, component outlines, documentation, and other artwork on the surfaces.
3. **Protective plating** — the exposed copper is coated with nickel or a metal alloy to prevent oxidation.

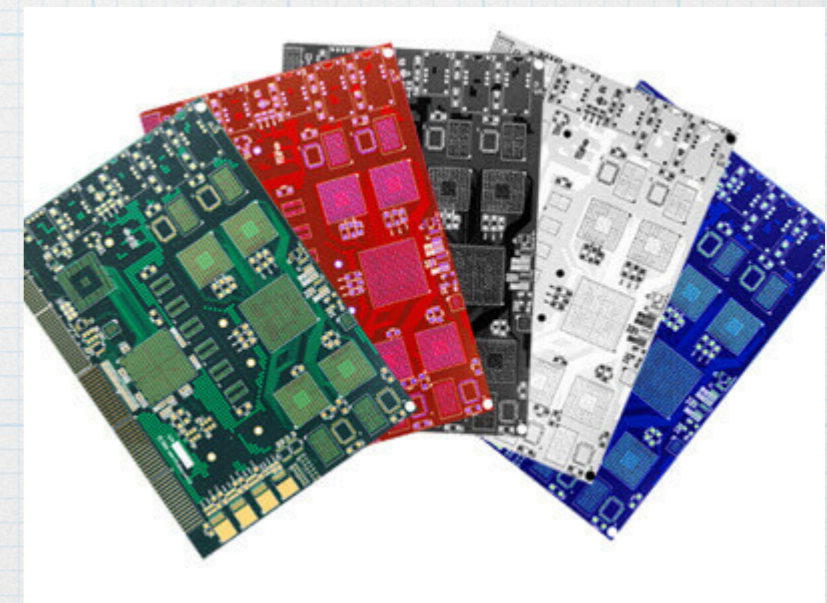
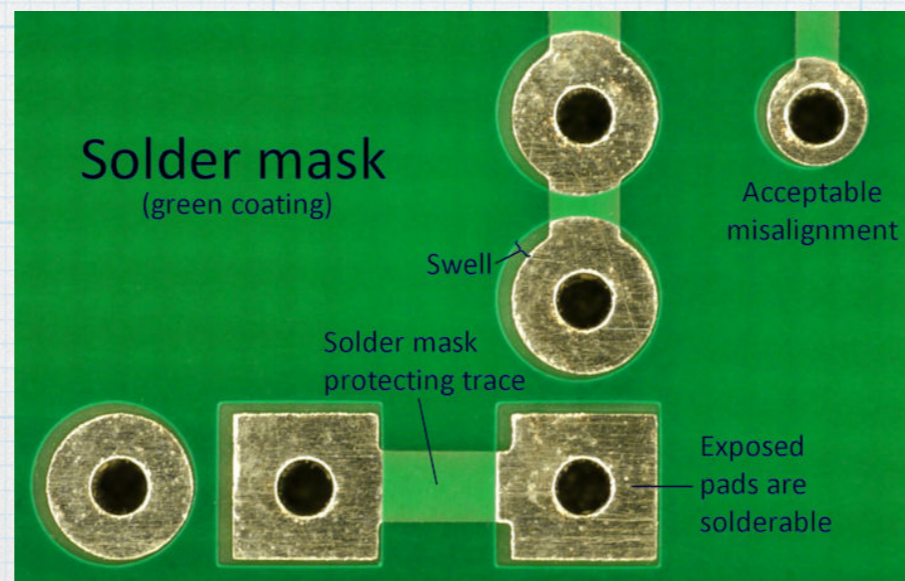
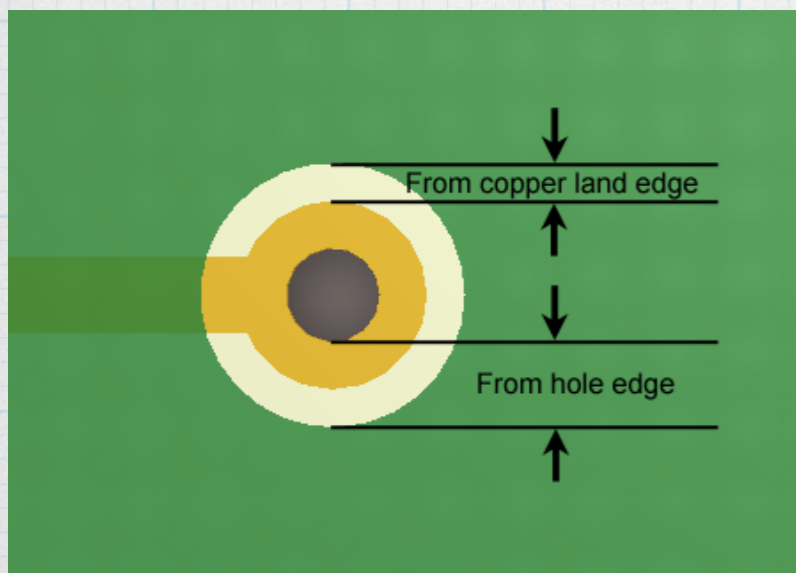

Multi-layer PCBs

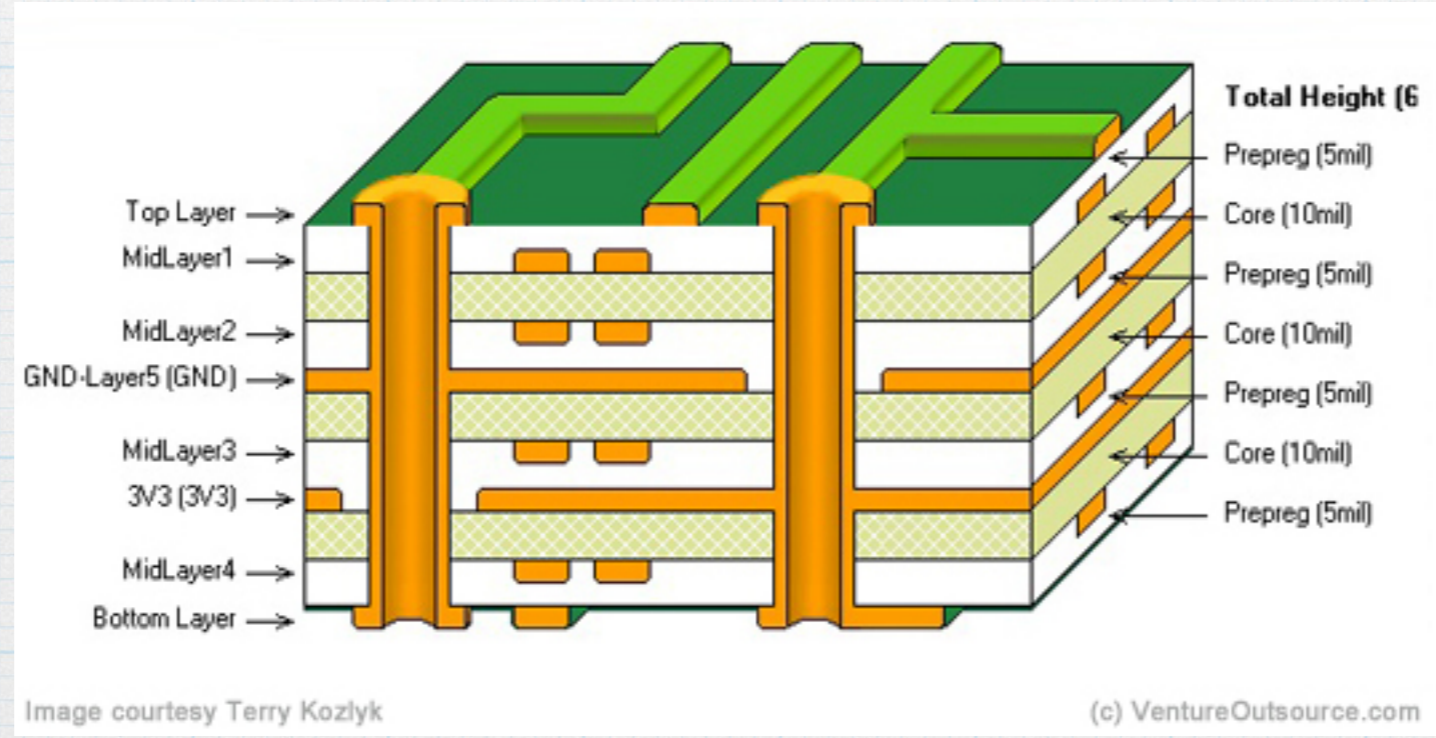
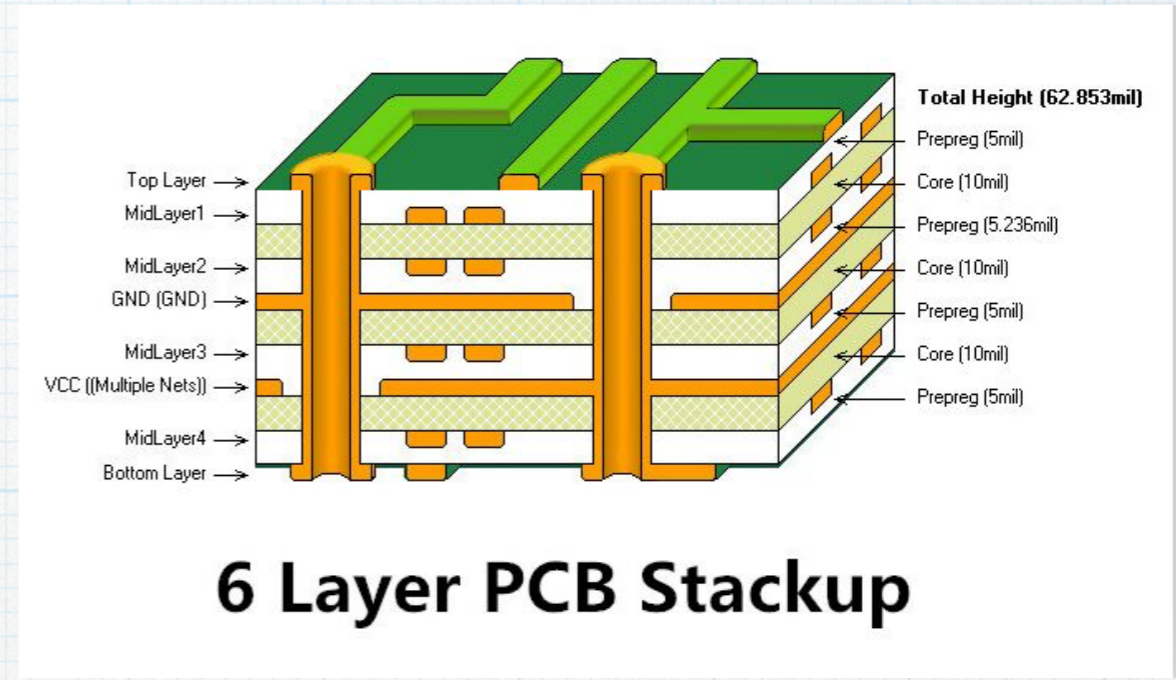
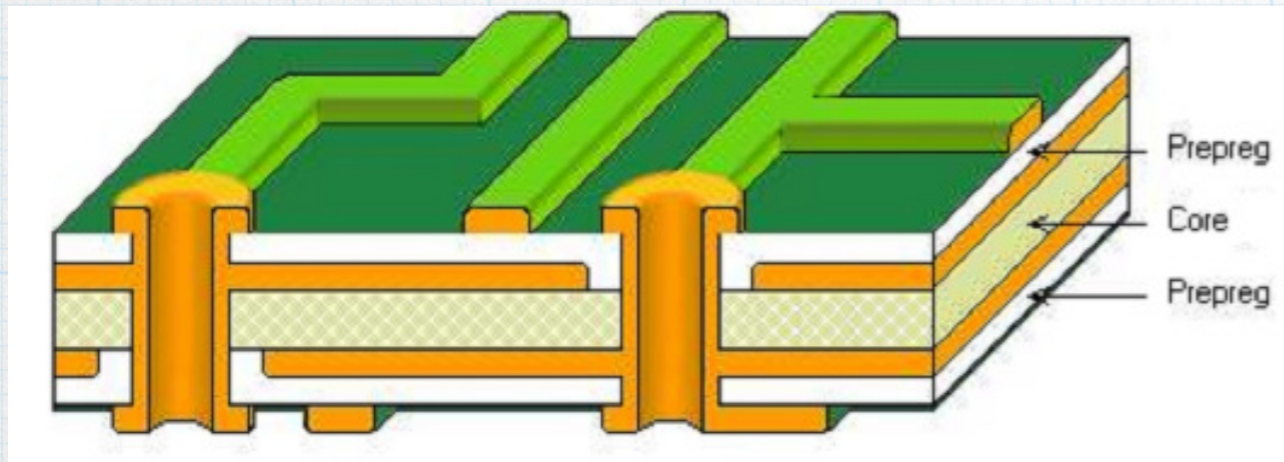

Skills required for prototyping and PCB design

1. Circuit analysis and design. (Duh.)
2. Laboratory measurement and test.
3. Breadboarding.
4. Using Digi-Key and Mouser to select components.
5. Soldering — for perboard prototypes and
6. PCB CAD tool(s).

Soldering for prototypes

1. Not an essential skill for engineers, but very good to know.
2. Many labs have soldering irons. Can learn through YouTubes, ETG seminars, audio/Arduino club, EE 333. Always good to have a mentor at first.
3. Keep everything clean. Flux is your friend!
4. Heat the wire, not the solder. Let surface tension to the work.
5. Don't use lead-free solder for prototypes. Lead-free solders have higher melting points and are harder to work with. (Do use them for manufacturing.)
6. Use a decent soldering iron with temperature control.
7. A vise or other holder can be useful.
8. A magnifying glass or microscope can be useful with tiny parts.
9. Solder wick or a solder pump is useful for removing parts during re-work.

Solder



<https://www.youtube.com/watch?v=Qps9woUGkvl>

Solder paste (reflow soldering)

Solder paste is a viscous liquid, formed by suspending tin-lead or tin-silver-copper alloy particles (essentially a powder) in a gooey combination of flux and liquid polymers.

The paste is deposited at the points where components will be soldered to the PCB. This can be done pad-by-pad using a syringe-like tool, or it can be done with a stencil.

The components are then placed on the board, with leads stuck into the drops of solder paste. The solder paste holds the components in place temporarily. (With chips, sometimes the parts are placed first and the leads are covered with solder paste.)

The PCB, with the components and solder paste, is then heated in an oven or with a heat gun to about 200°C or so. The paste melts into a much less viscous liquid, with some of the flux evaporating. Surface tension causes the paste to flow to the metallic pads and component contacts. It tends not to stick in the areas covered in solder paste. When the assembly is allowed to cool, the paste solidifies, forming a good electrical and mechanical contact between the board and component lead.

Solder paste video



https://www.youtube.com/watch?v=4Z1B_DbW-C0

Again, this can all be done in an oven, rather than using a hot-air gun.
ETG has solder paste and a reflow oven — see Lee in the shop for help.

Perf board

No (or few) traces but great for initial prototyping for through-hole designs. Holes are spaced with the usual 0.1" x 0.1" spacing.

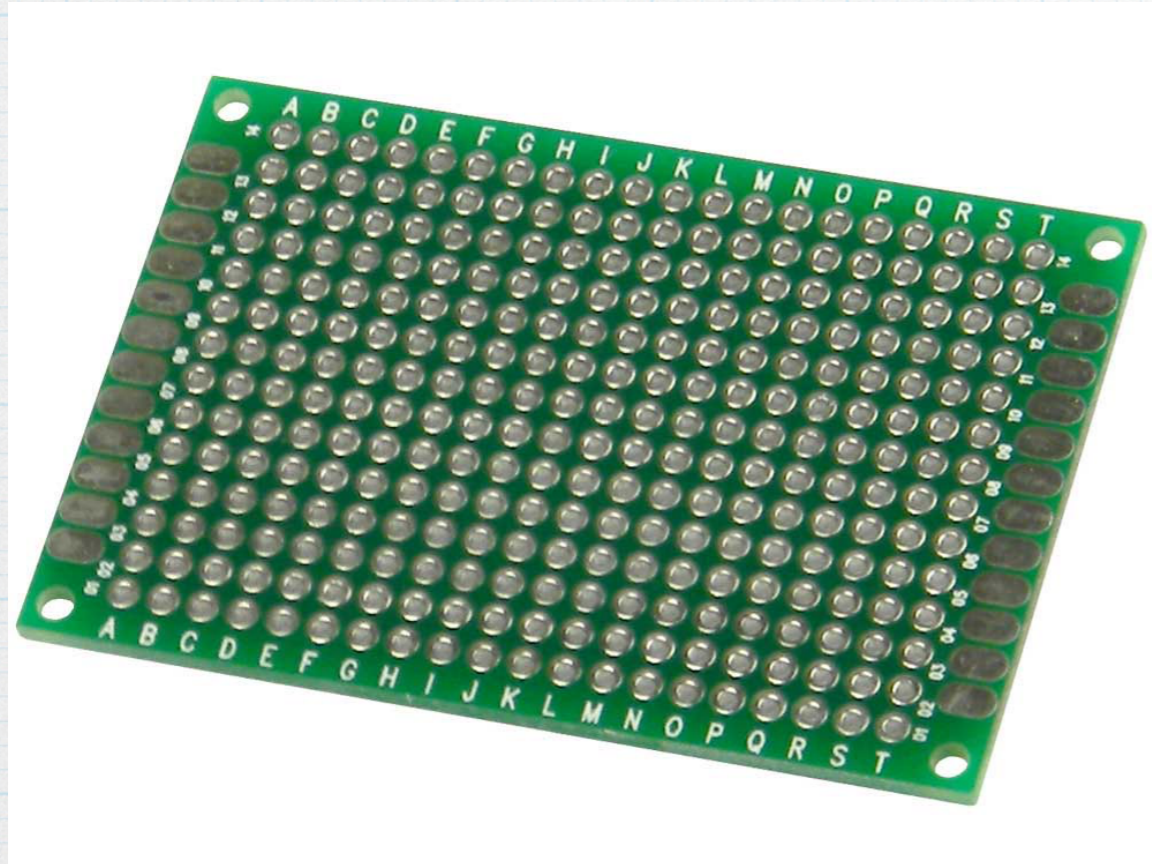

Plated through hole.
Various sizes.

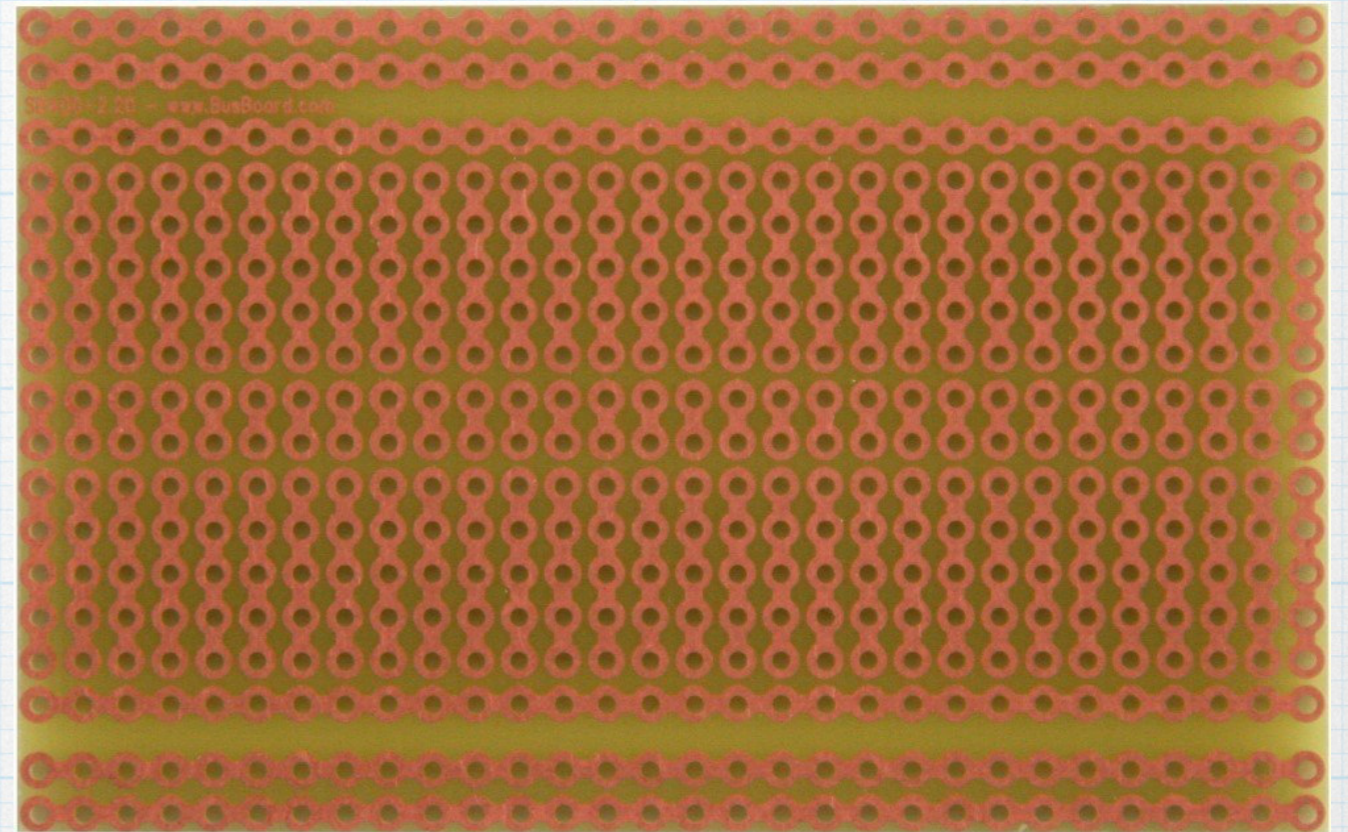

SB400. metal on one side only,
but some holes are connected.
(Similar to solder-less
breadboards in EE 201.)

Two steps in prototyping

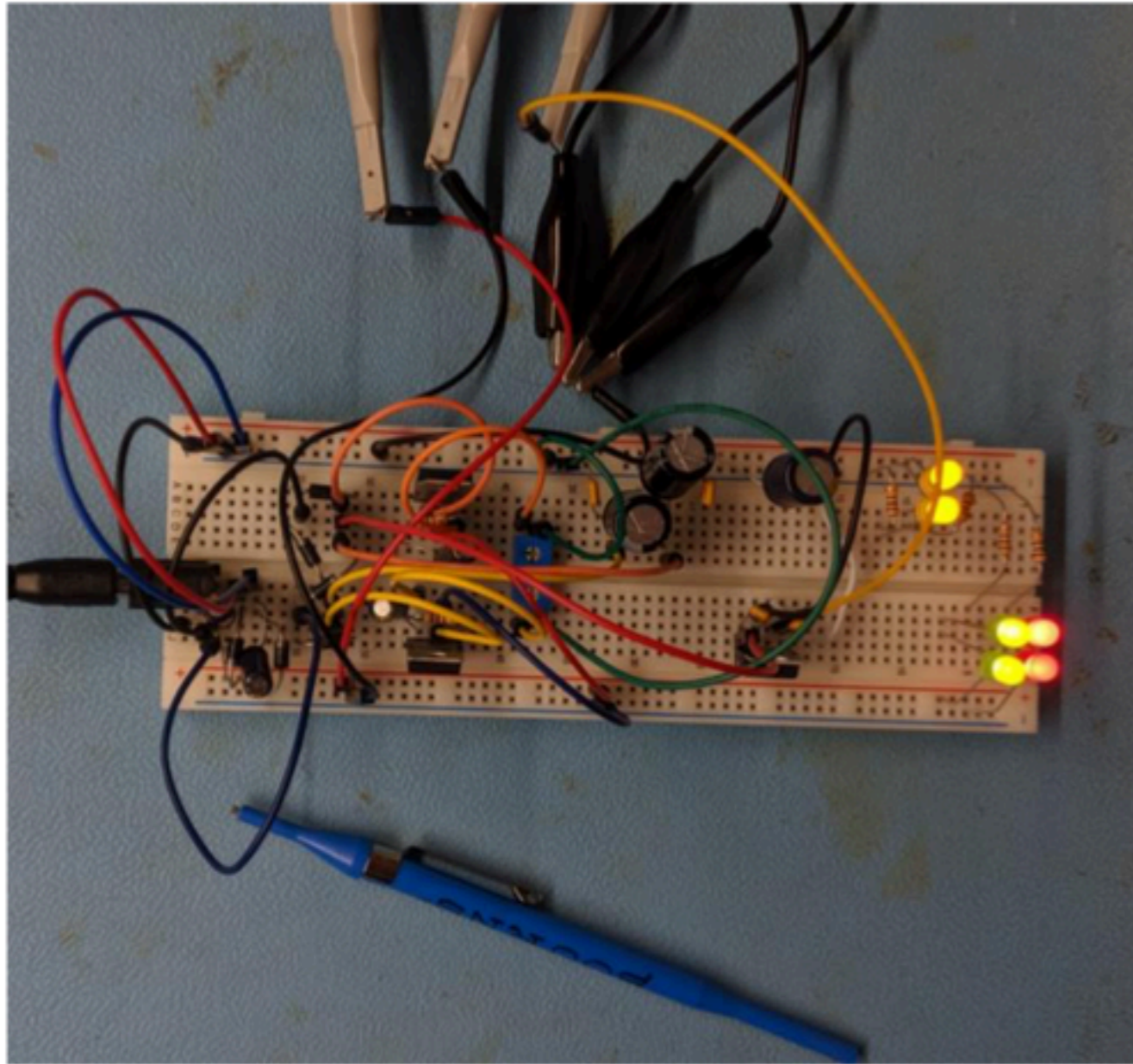

Breadboard (like EE 201/230)

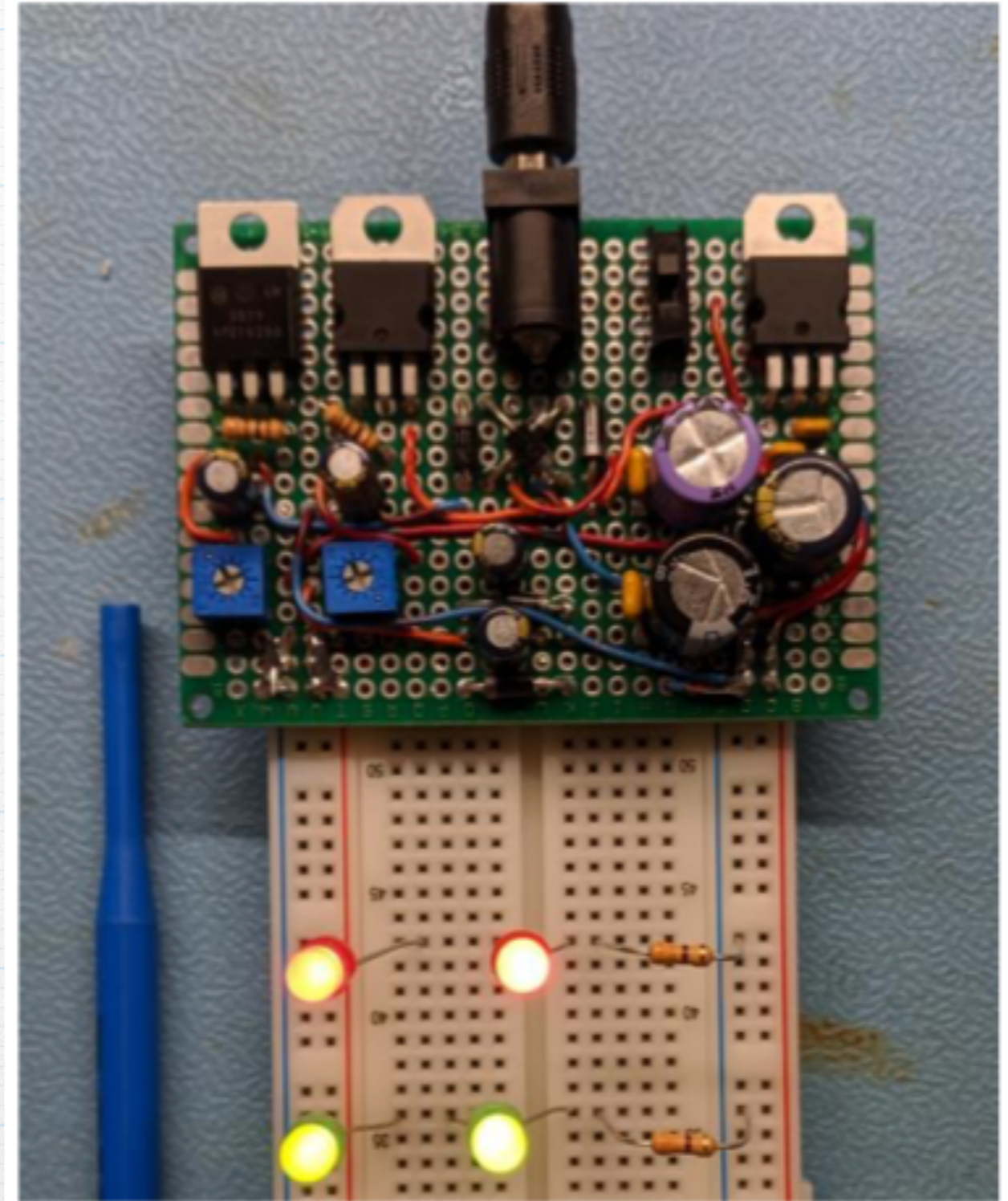

Perfboard.

For prototyping surface-mount parts, there are break-out boards available. Solder the SM part to the break-out board, solder pins to the outer connections of the board, and insert the whole thing into a standard through-hole breadboard.

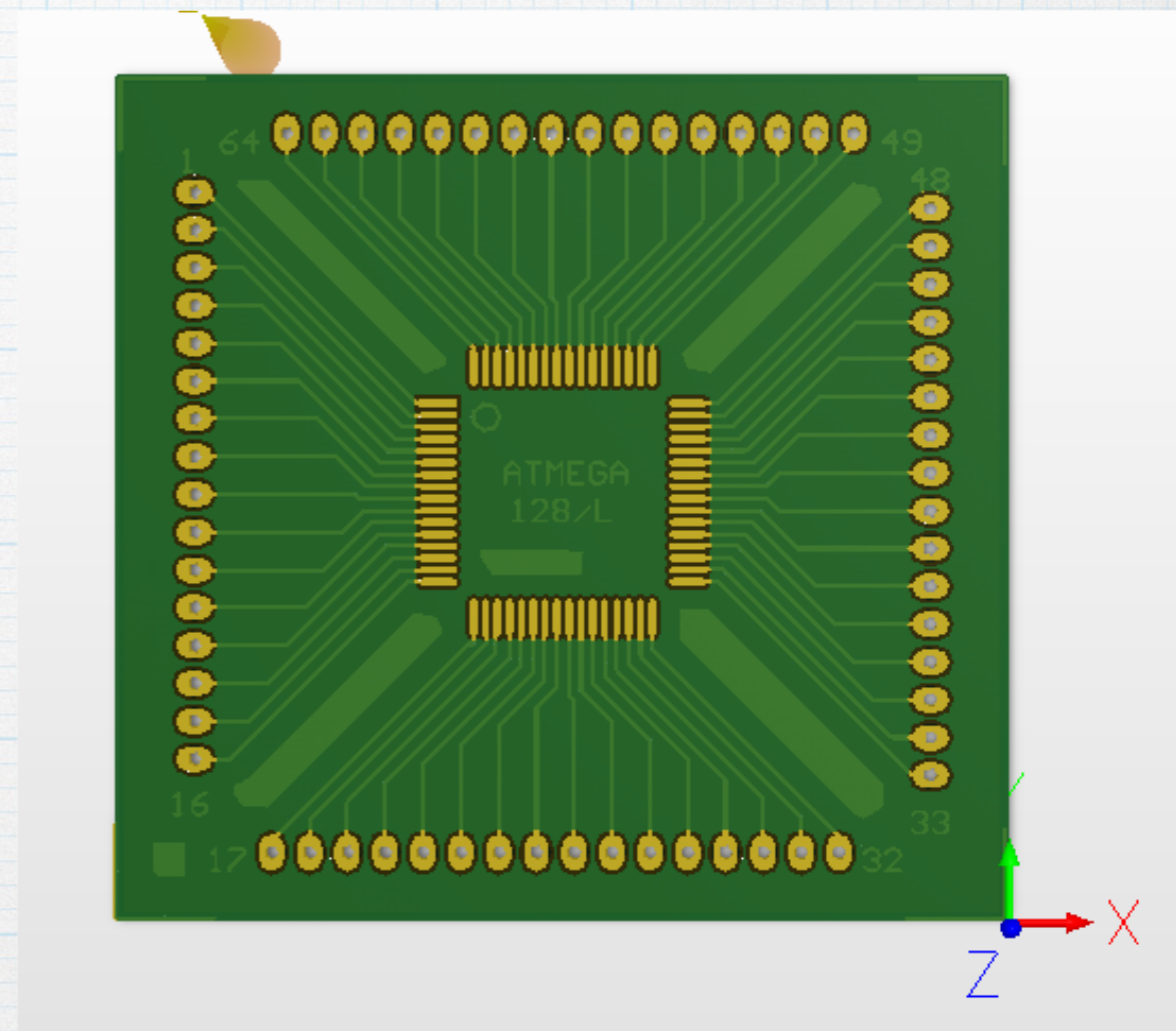

Designing a PCB.

CAD packages:

- KiCad – Free, open-source software. Used in EE 333.
- Eagle (Cad-Soft) – Available for Windows, Mac, and Linux. Free student versions available (limited capabilities), along with paid versions that are unlimited.
- Altium – Windows. Commonly used in industry.
- OrCAD – Windows.
- Multi-Sim / Ulti-board (National Instruments) – Windows only. The ECpE department has a license. Formerly used in EE 333.
- Many PCB fab houses provide free layout tools.
- and more...

There is a series of eleven videos from DigiKey that pretty good at showing how to use KiCad. Start with <https://www.youtube.com/watch?v=vaCVh2SAZY4> and work your way through. About 2 hours total.

The CAD process

Starting with a paper design:

1. Draw up a circuit schematic, *using the components with the proper “footprints”*. This is similar to drawing circuit in LTspice or PSpice, but you must specify the exact parts you plan to use in your design. You will also include things like connectors that are typically ignored when doing a SPICE simulation.
2. The circuit schematic is transferred over to a board schematic, which shows the physical arrangement of the parts.
3. Arrange the parts on the board and adjust the board size.
4. Draw traces that connect the various components together.
5. Make adjustments to trace widths, lettering, etc.
6. Design-rule check (optional ?)
7. Generate Gerber files.
8. Send Gerbers to the PCB fabricator along with some money. Wait patiently for the boards to come back.

Some highlights of the process.

The circuit is simple head-phone amplifier, usually built as a project in the Audio club. The tutorial uses Multi-Sim / Ultiboard.

1. Draw a schematic circuit schematic in Multi-Sim.

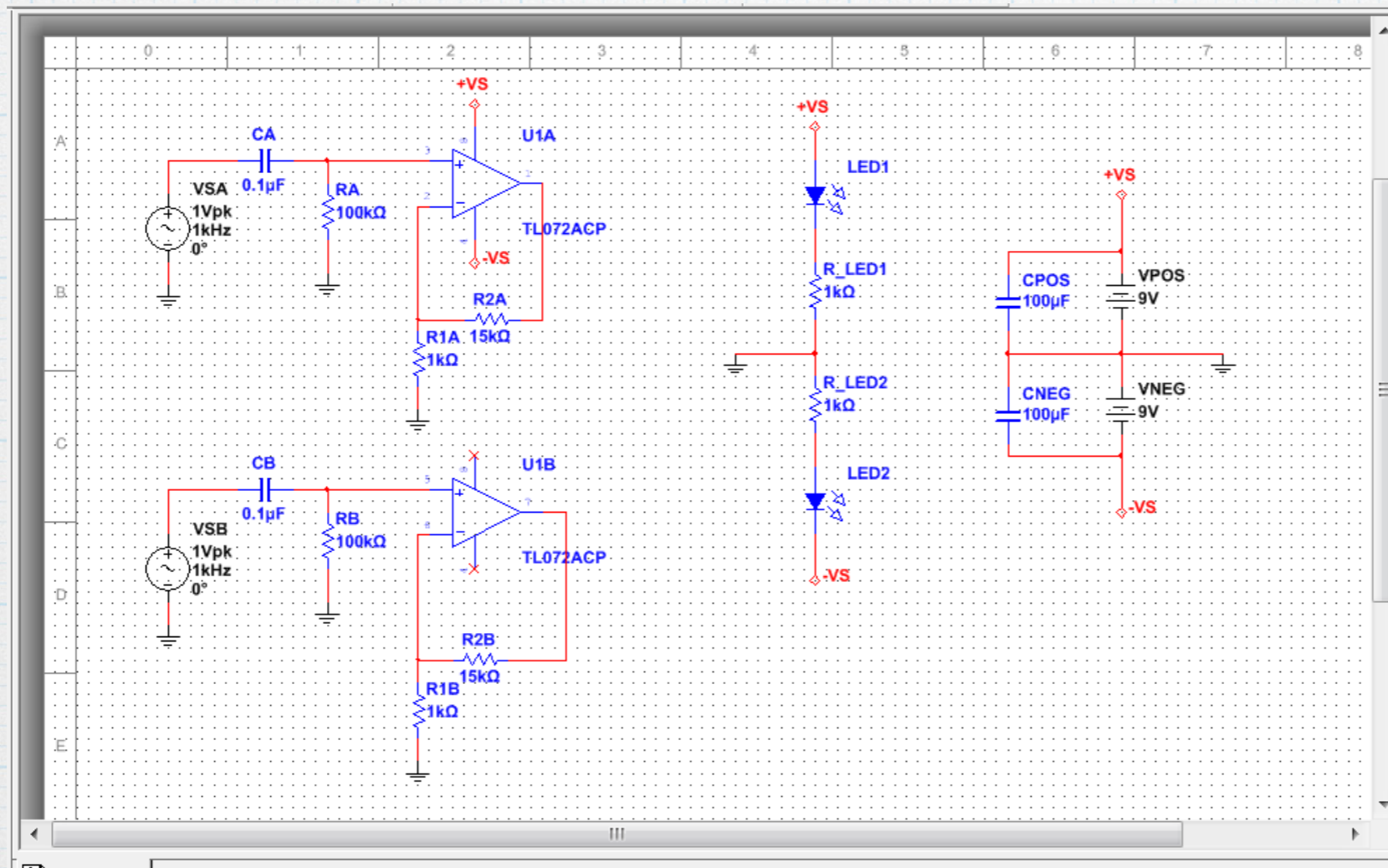

1a. In choosing “parts” for the schematic, you must be specific to the particular footprint that matches the part you will use.

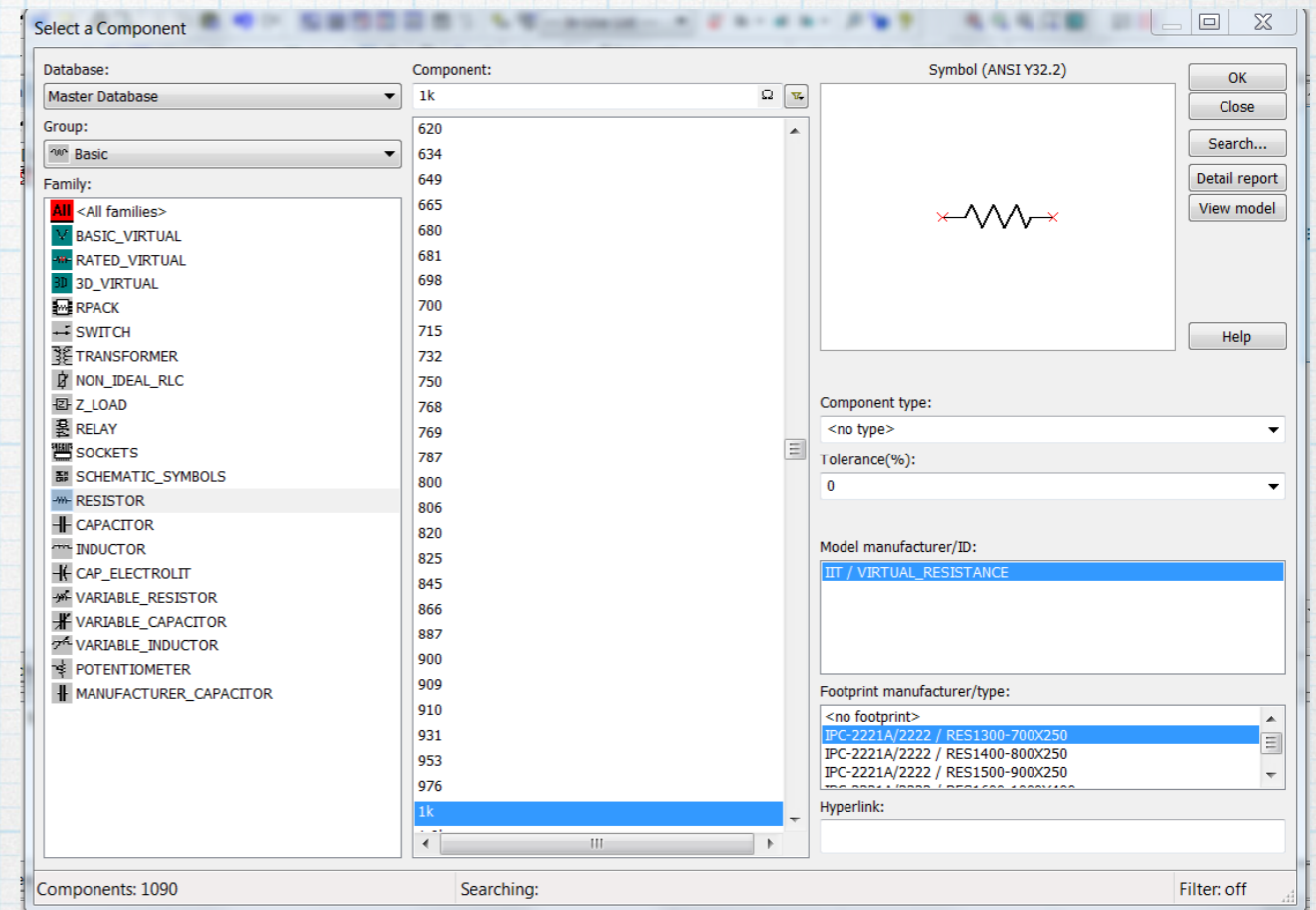
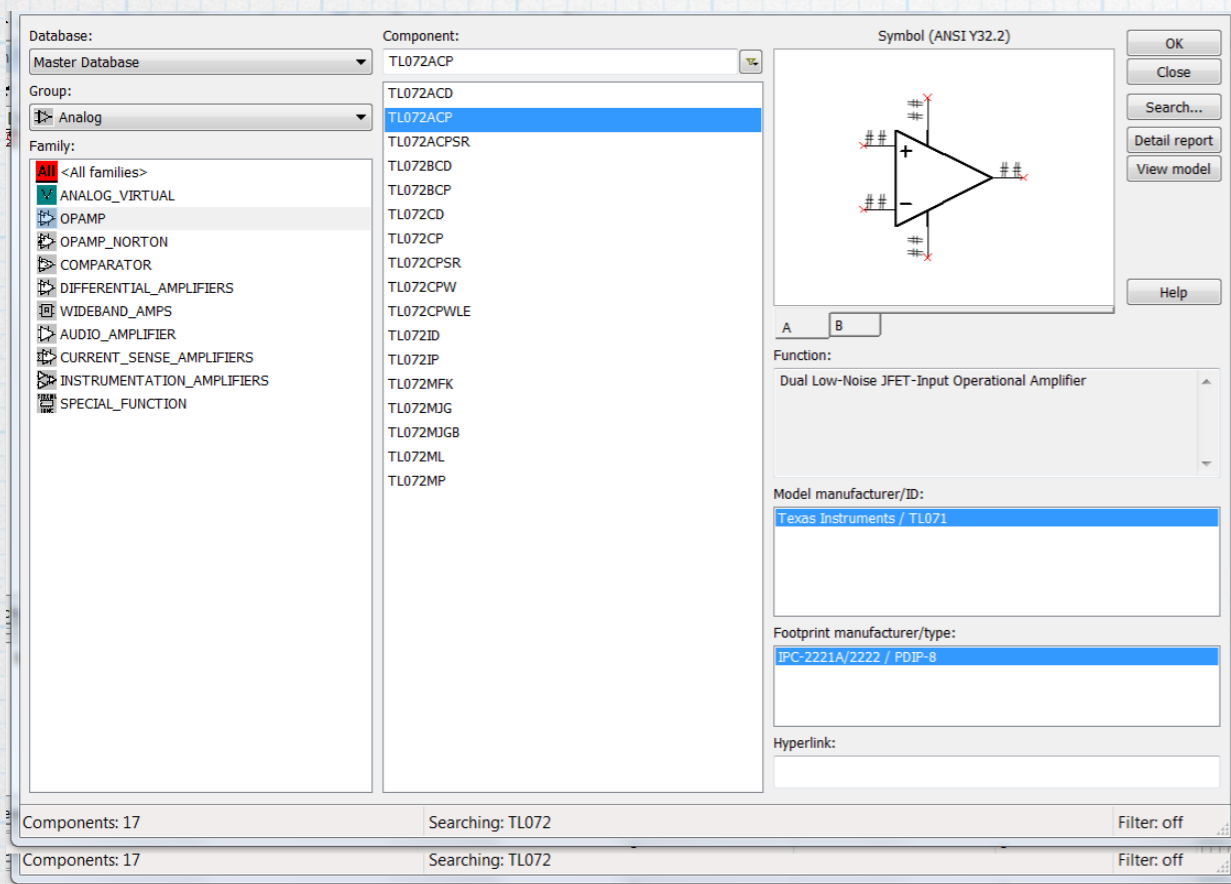

1b. Make adjustments for connectors rather than generic sources and loads.

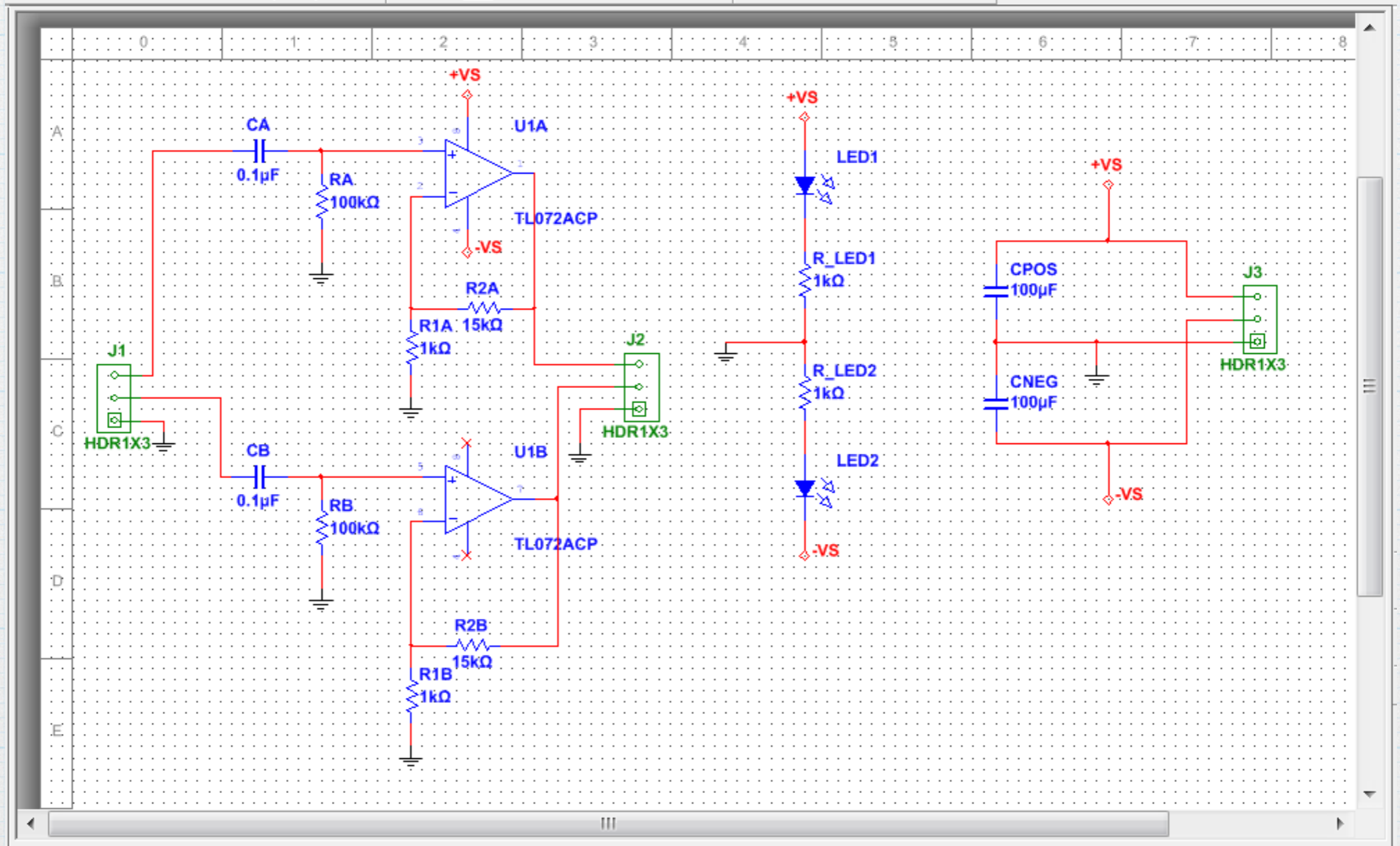

2. Transfer the circuit schematic to the board layout view (Ultiboard).

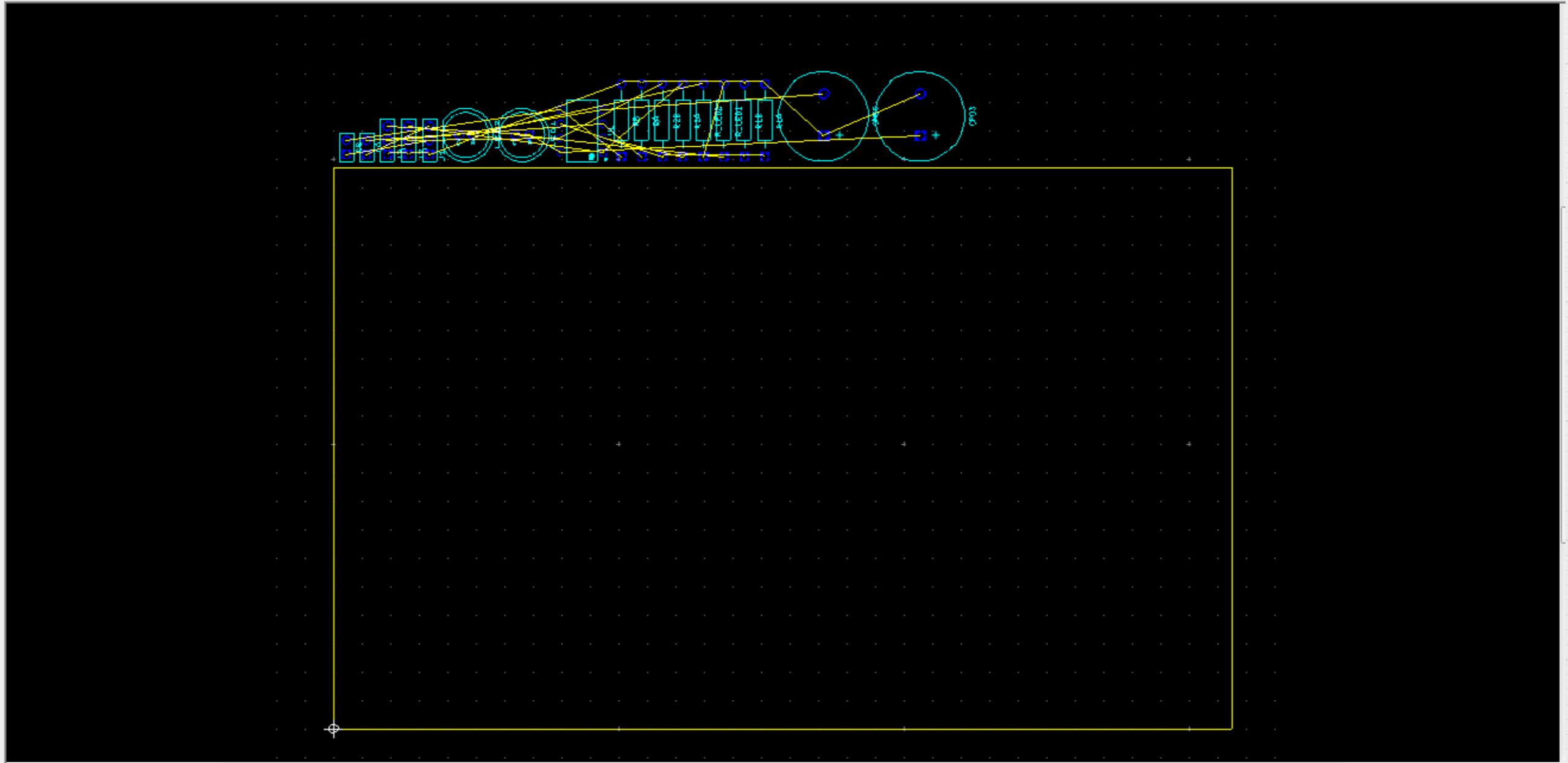

3. Adjust the board size and move all of the parts inside the board outline. Arrange them however you want. The electrical connections are indicated by “rats-nest” lines.

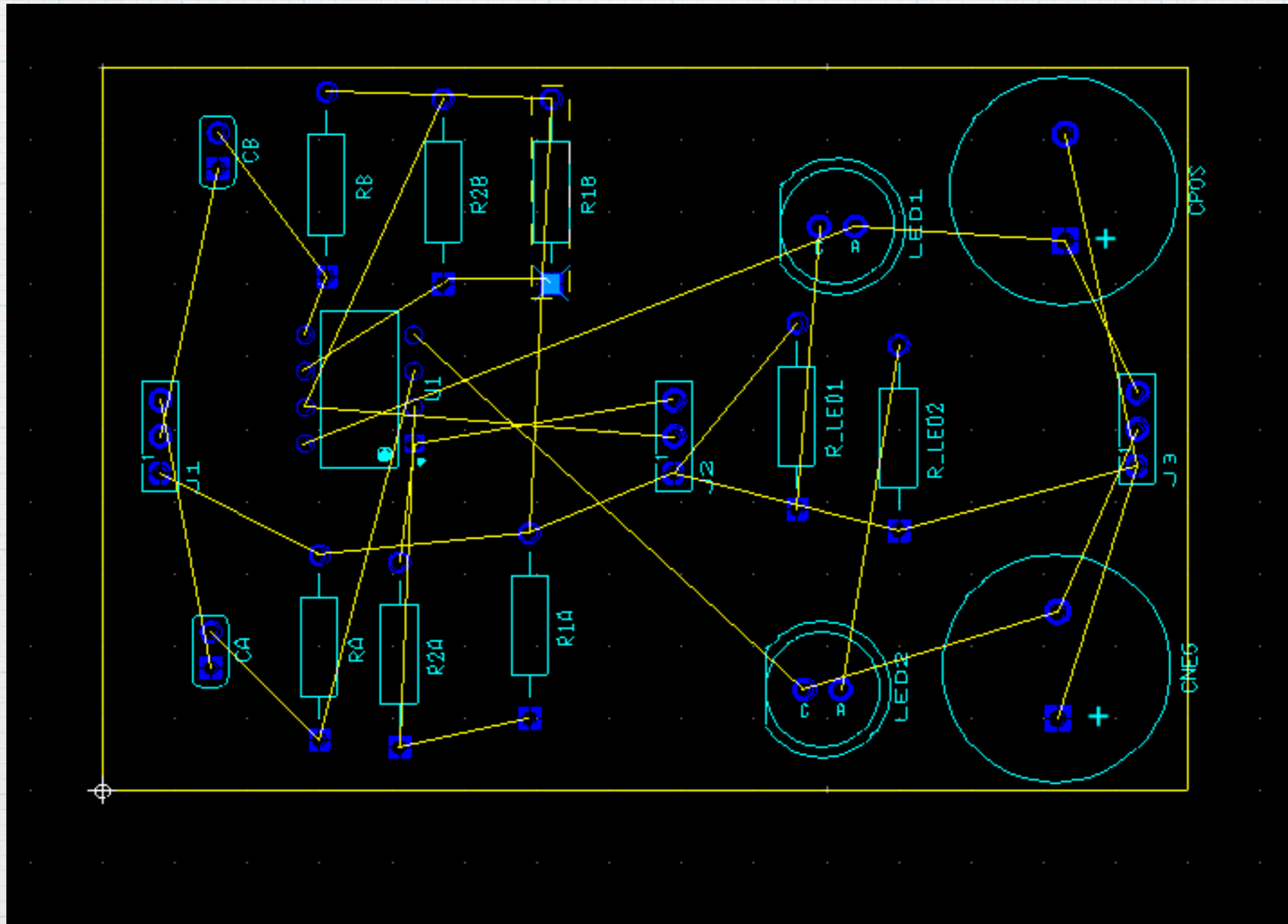

4. Define a ground plane (or planes). (optional)

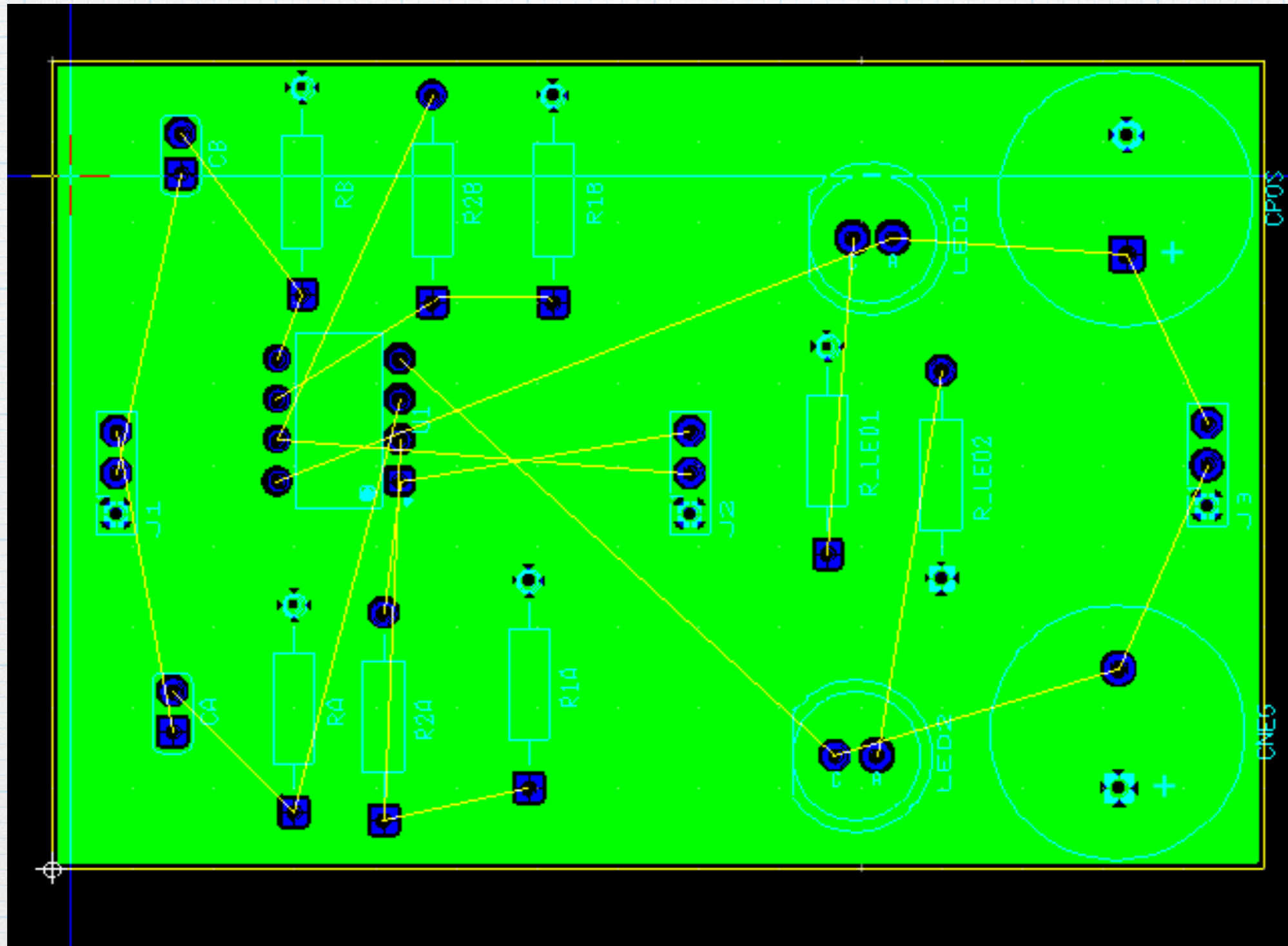

5. Draw traces to interconnect the (non-grounded) leads on the components.

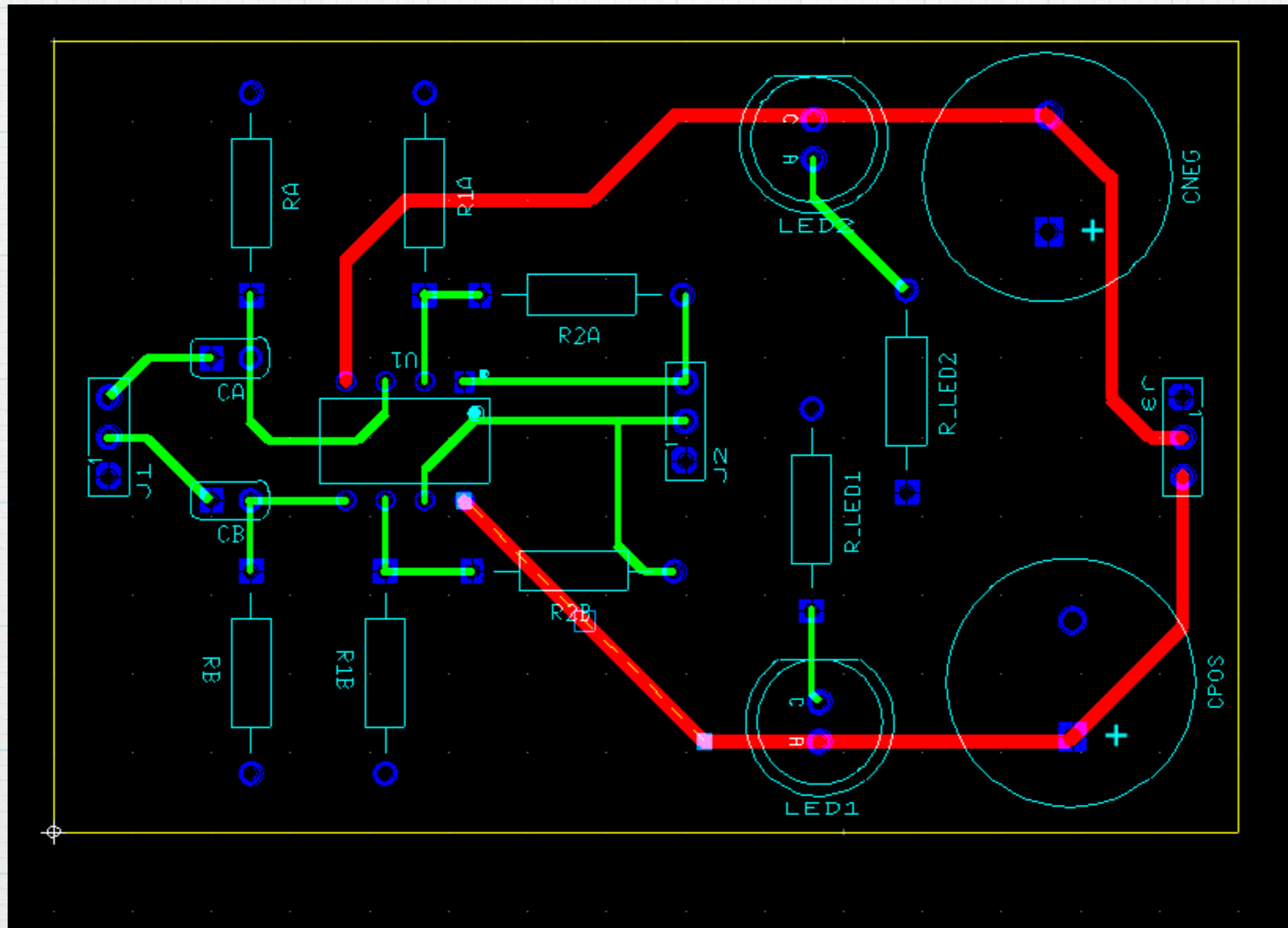

6. When finished with interconnects, make trace widths adjustments and fine-tune details.

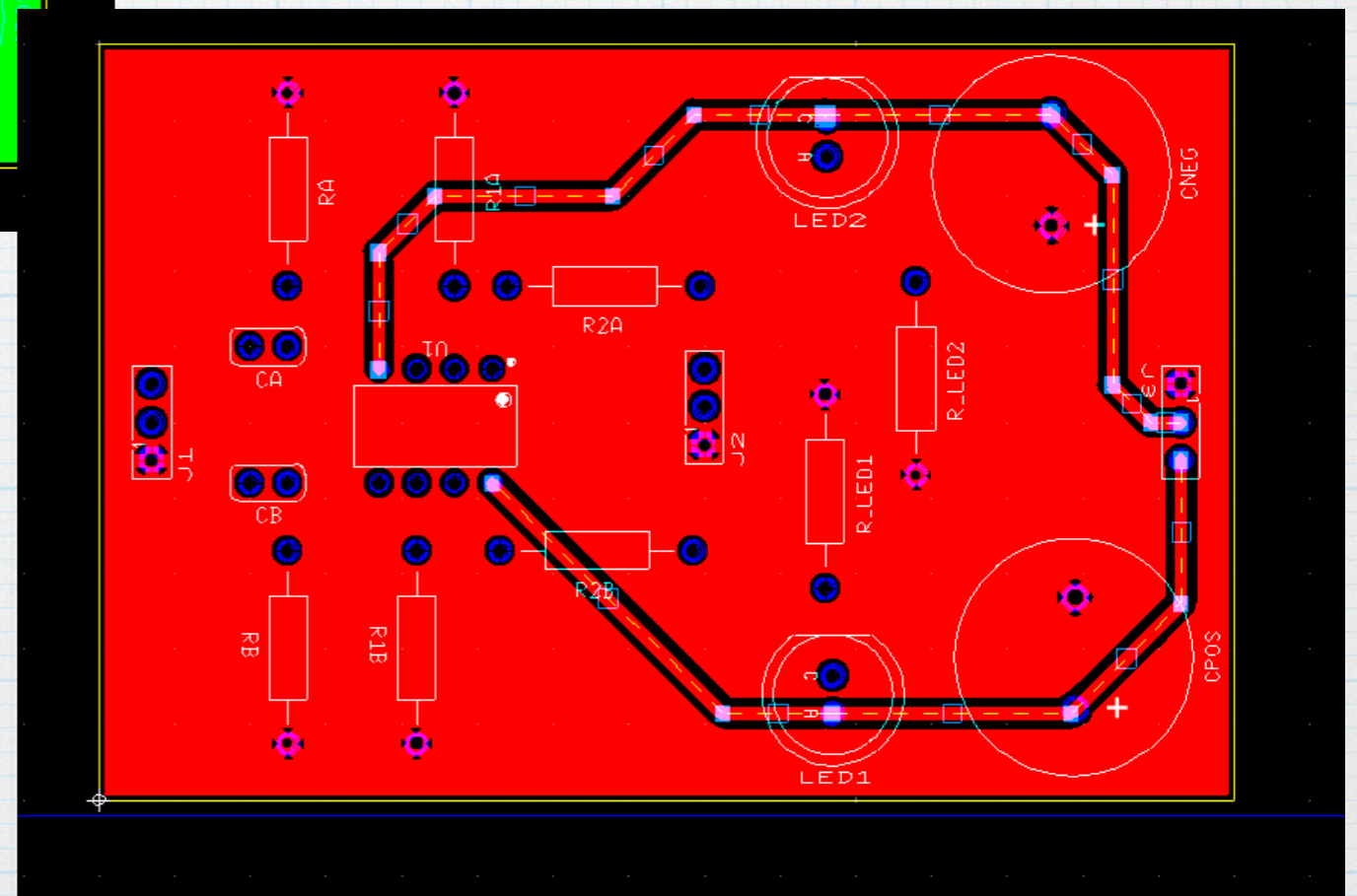
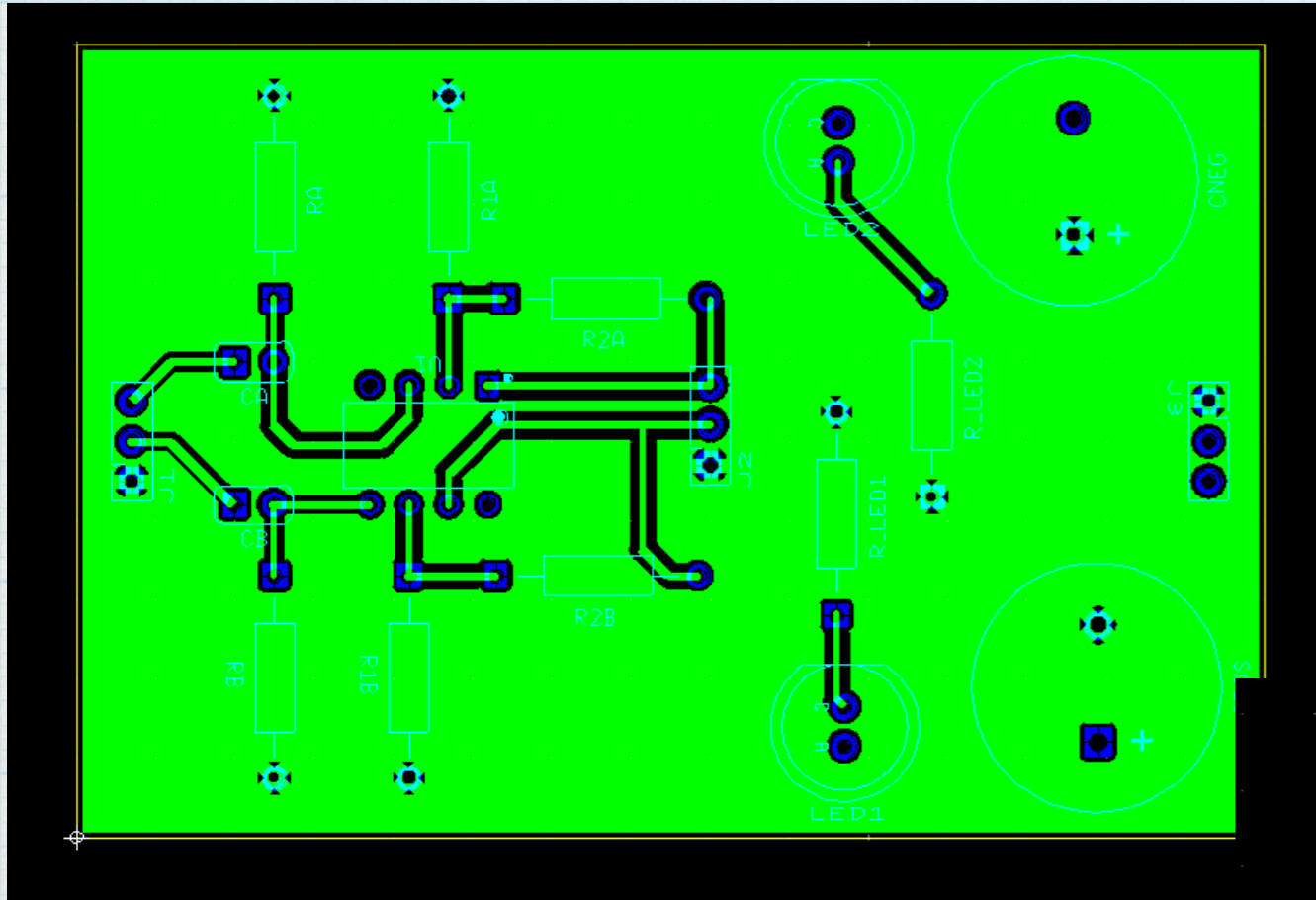

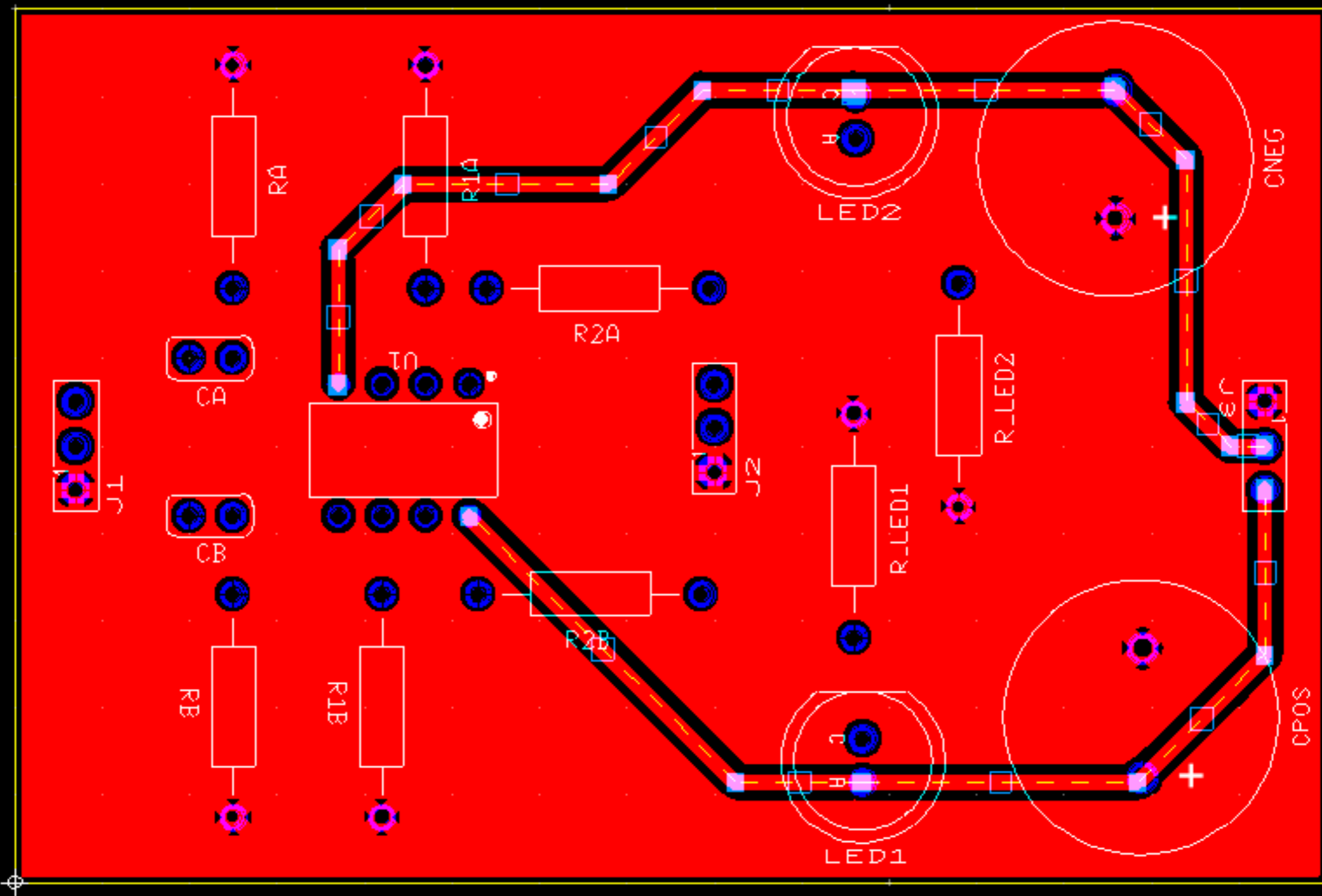

6. Do a design-rule check (DRC).
7. Convert Ultiboard CAD file to Gerber files — one Gerber for each layer and one for the drill holes.
 - i. Top copper pattern
 - ii. Bottom copper pattern
 - iii. Top solder mask
 - iv. Bottom solder mask
 - v. Top silk screen (lettering and outlines)
 - vi. Bottom silk screen (if used)
 - vii. Board outline
 - viii. Drill holes (location and diameter).
8. Zip up all the files and send them off to the manufacturer.

PCB fabricators

There are literally thousands available, all over the world. Here are three that I have used:

- Oshpark (<https://oshpark.com>) – Located in Oregon. Great for small-scale prototyping, for small companies, classes, and hobbyists. Pay by the square inch. \$5 per square inch for two-layer boards, \$10 per square inch for four layers. You get three boards at that price. Distinctive purple solder mask. Typically takes about two weeks.
- Advanced circuits (<http://www.4pcb.com>) – Located in Colorado. A single two-layer board, up 60 square inches (??) for \$33. Turn around is about 8 days.
- PCB Fab Express (<https://ecommerce.pcbfabexpress.com>) – Located in California. No students offerings, but they have decent prices for standard work. Turn-around time is based on how much you are willing to pay.
- SEED Studio (<http://seedstudio.com>) – Located in China. Very inexpensive. Fairly fast. Similar to many other Chinese vendors.

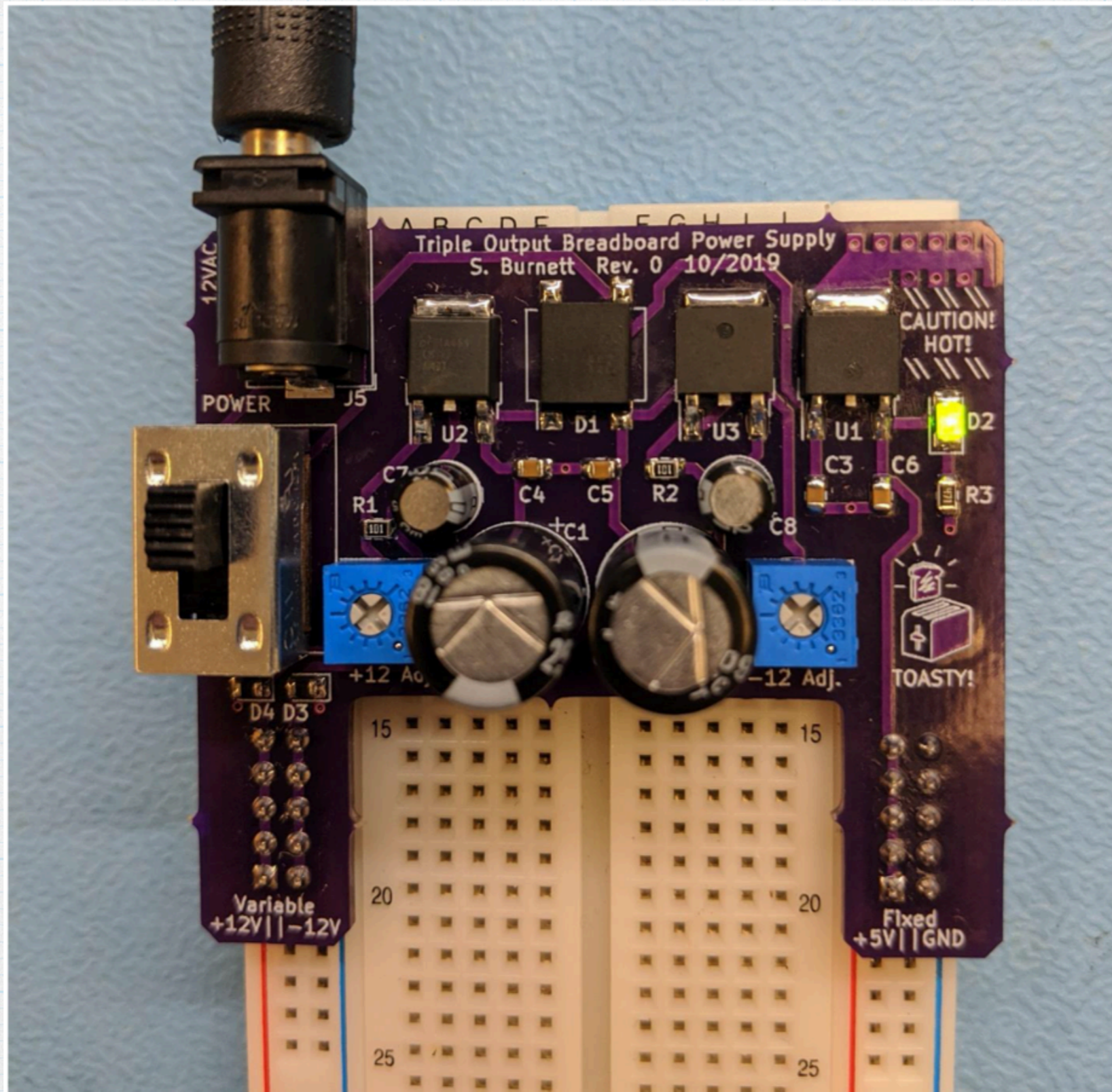

The finished –and working – PCB.

CNC milling

- Great for prototyping. You can go from design to soldering parts in a few hours.
- Too slow for production. Also, missing some features (plated through-holes, solder mask, silk screens, etc).



<https://www.youtube.com/watch?v=I9SwoUCcFVU>

See Lee in the ETG shop to use the department's CNC mill.

Board fabrication

The PCB fabrication process is very detailed and very interesting. Too much to go through now, but here are a couple of videos that show the process at two different fab facilities.

- https://www.youtube.com/watch?v=sIV0icM_Ujo
- <https://www.youtube.com/watch?v=rEB0pl8a5C0>

Board assembly: pick-and-place machines

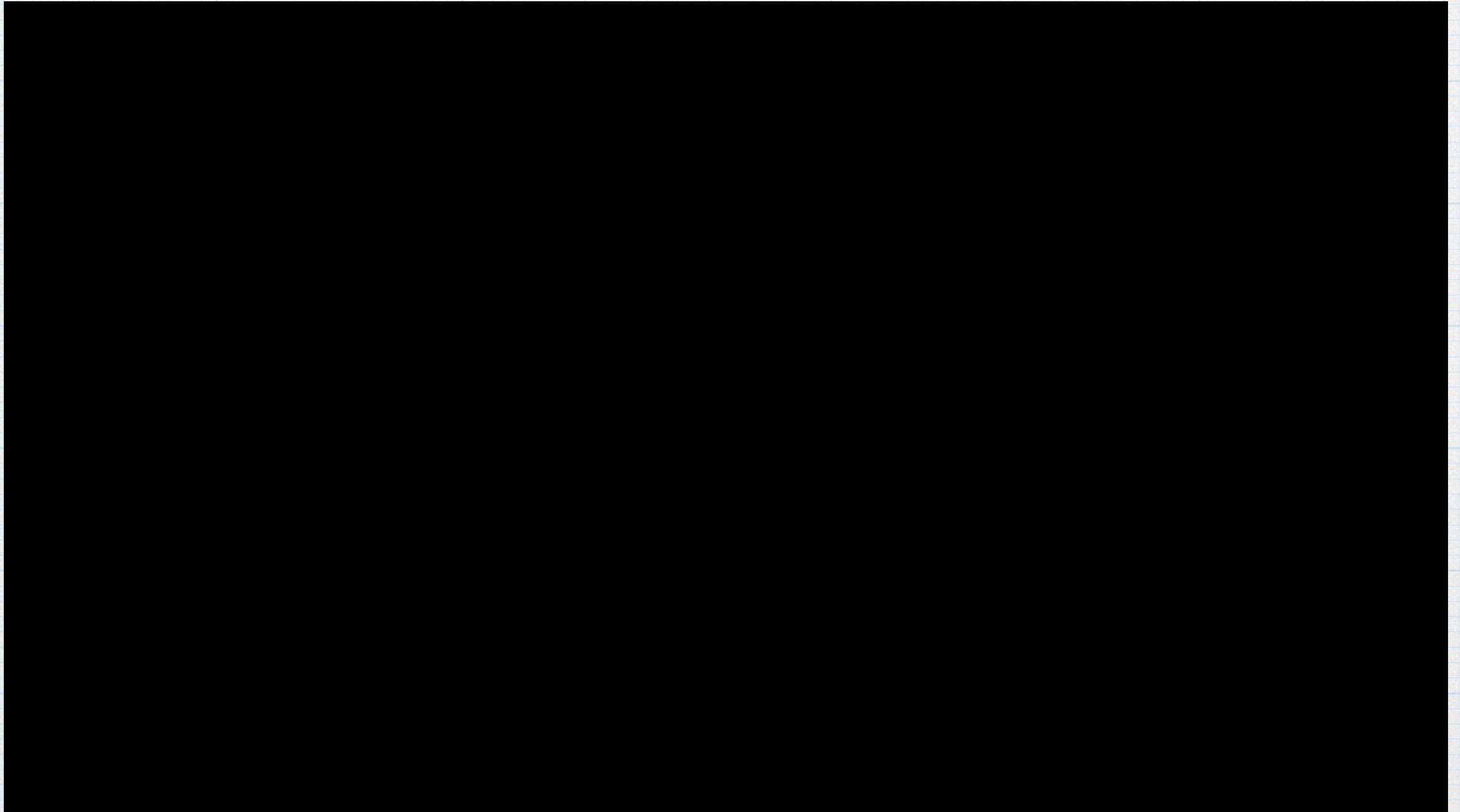

Pick-and-place machine (fast!)

