

Operational amplifier circuits

This week, we look at some simple op-amp circuits.

In lab, we will use the venerable LM324 operational-amplifier array as the central component in several circuits. The LM324 are is a *general purpose* amplifier, with decent specifications in most of the parameters that characterize op amps. A data sheet for the LM 324 can be downloaded from the web site. There are a number of different types of packages for integrated circuits. The package we use here is the 14-pin DIP (dual in-line package), which plugs easily into the breadboards. Note that there is no specific ground connection. The ground for an op amp circuit is defined by the common connection for the power supplies (or in some cases, single power supply).

The *pin out* arrangement for the LM 324 package is shown at right. It can also be seen in the data sheet. Each chip package has an orientation mark – either a semi-circular cut-out along a short side or a small circular mark in one corner. Both are indicated in the figure. Viewed from the top (with the pins pointing *away* from you) with the marks on the left-hand side, the pins are numbered as shown.

It is important to make certain that you do not mix up the power supply connections. If the supply polarities are backwards, there is a good chance that the op amps will burn out.

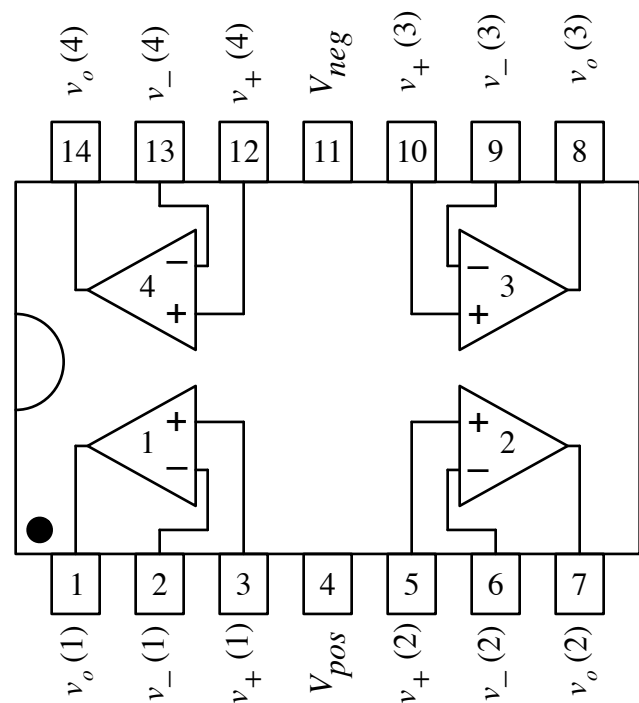

Wire up each of the five circuits described below and apply the required input voltage(s). In each circuit, use power supply voltages of +10 V and -10 V for the op amps. (For the first couple of circuits, you may want to have the lab instructors check the connections *before* you turn on the power supply.) Bring a flash drive so that you can save copies of waveform traces to include in your lab report. (You may also want to review oscilloscope operation, since we have not used the scope for a while.)

Finally, when setting up the function generators, don't forget to set the output to "High Z" and the units to V_{RMS} .

If you would like to do the optional stereo amp at the end, you should bring along a pair of standard earphones or earbuds.

1. Non-inverting amplifier

Using one of the op amps from the LM 324 array, build the non-inverting amplifier circuit shown at right. Measure the resistors, so that you know their precise values.

For v_s , use the function generator set to a sinusoid with frequency of 1000 Hz and amplitude of $0.5 V_{\text{RMS}}$.

Then follow the steps outlined below.

- Calculate the expected gain, $G = v_o/v_s$ for the circuit.
- Measure the gain by measuring the output voltage and input voltage with the multimeter and calculating the ratio.
- Observe the input and the output together on the oscilloscope. Adjust the vertical scales so that you can clearly see the input sinusoid and the amplified output sinusoid. Save a copy of a clear trace to put in your lab report.
- Use the dial on the function generator to increase the amplitude of the input sinusoid to $1 V_{\text{RMS}}$. Note what happens to the output waveform as the input is increased. This is *clipping* — the output cannot be bigger than power supply voltages. Now use the dial on the power supply to increase the positive supply voltage. Ramp up the voltage until the upper half of the output sinusoid is no longer clipped. Then ramp down (i.e. make more negative) the negative supply until the negative half of the output sinusoid is no longer clipped. The relationship between power supply levels and maximum output voltage is fairly obvious — the output can't produce more more than what is available from the power supplies. Return the power supply levels to ± 10 V. Save a copy of the input and clipped output sinusoids for the report.

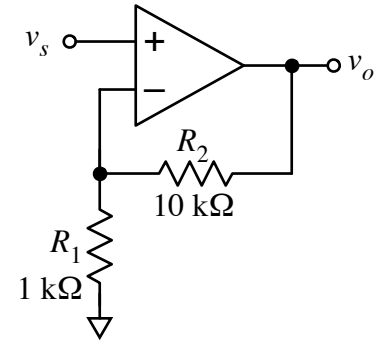

2. Inverting amplifier

Build the inverting amplifier circuit shown at right. Measure the resistors, so that you know their precise values.

For v_s , use the function generator set to a sinusoid with frequency of 1000 Hz and amplitude of $0.25 V_{\text{RMS}}$.

- Calculate the expected gain, $G = v_o/v_s$ for the circuit.
- Measure the gain by measuring the output voltage and input voltage with the multimeter and calculating the ratio.
- Observe the input and the output together on the oscilloscope. Save a copy of the input and output traces to put into your report.

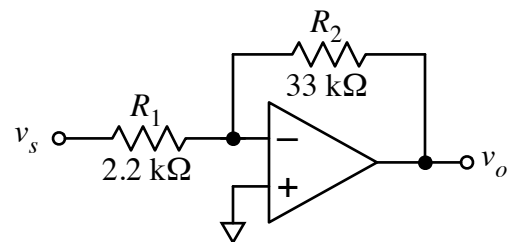

3. Summing amplifier

Build the summing amplifier circuit shown at right. Measure the resistors, so that you know their precise values. For v_{ac} , use the function generator set to a sinusoid with frequency of 1000 Hz and amplitude of 0.5 V_{RMS}. For v_{dc} , use the third DC output (0-5V) of the triple DC supply – be sure to connect its negative terminal to the common for the positive and negative supplies.

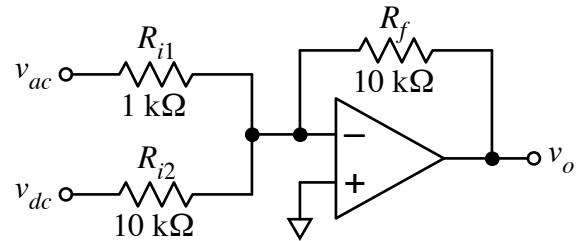

- Calculate the expected output function for the circuit.
- Observe the input and the output together on the oscilloscope. Note the summing action by varying the DC voltage from 0 to 3 V and noting the effect on the output. Record oscilloscope traces for two different values of v_{dc} . Note that the output will clip at higher value of v_{dc} .
- Measure the gain of the *ac path* by making $v_{dc} = 0$ (connect it to ground) and measuring the output (v_o) and the AC input (v_{ac}) and calculating the ratio.

4. Difference amplifier

Build the difference amplifier circuit shown at right. Measure the resistors, so that you know their precise values.

For the source voltage, use the function generator set to a sinusoid with frequency of 1000 Hz and amplitude of 0.5 V_{RMS}.

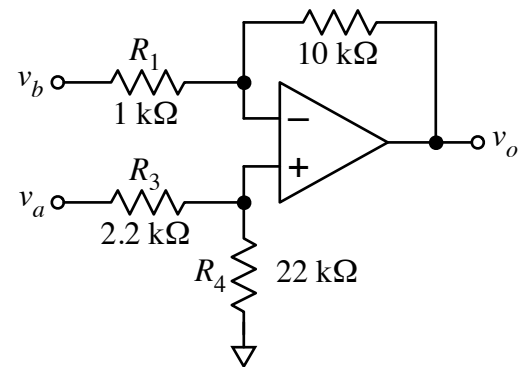

- Calculate the expected output for the circuit, in terms of the two input voltages and the resistors.
- Set v_b to 0 V (connect it to ground) and connect the source to v_a . Measure the difference-mode gain, $G_d = v_o/v_a$ by measuring the output voltage and input voltage with the multimeter and calculating the ratio. Observe the input and the output together on the oscilloscope. Save a copy of a clear trace to put in your reports.
- Swap the the inputs (connect v_a to ground and v_b to the sinusoid). Measure the gain in this case. Observe the input and the output together on the oscilloscope. Note the difference between this trace and the one seen in part b. Save a copy of a clear trace.
- Lastly, connect v_a and v_b both the sinusoidal source and increase the source amplitude to 5 V_{RMS}. Measure the output voltage. (What happened to it!). Calculate the common-mode gain, $G_c = v_{oc}/v_s$ and the common-mode rejection ratio, $CMRR = G_d/G_c$. (G_c should be small and CMRR should be big.)

5. Cascaded amplifiers

Using two op-amp on the LM324 chip, build the cascaded amplifier circuit shown below.

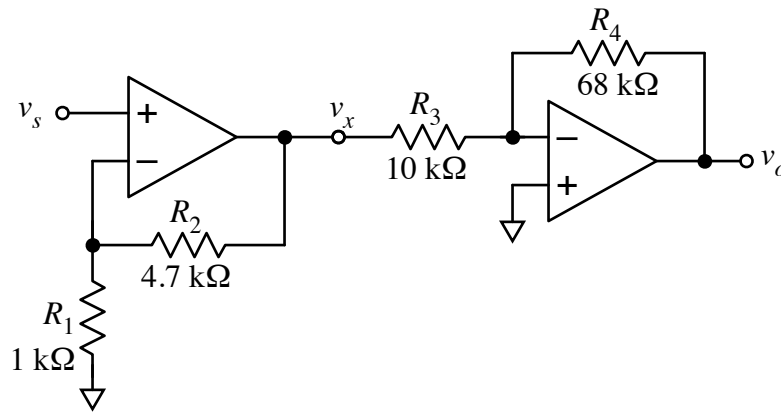

For v_s , use the function generator set to a sinusoid with frequency of 1000 Hz and amplitude of $0.25 V_{\text{RMS}}$.

- Calculate the expected gain, $G_{12} = v_o/v_s$ for the circuit.
- Observe the input and the output together on the oscilloscope.
- Use the multi-meter to measure the following gains: $G_1 = v_x/v_s$, $G_2 = v_o/v_x$, and $G_{12} = v_o/v_s$.
- Save a copy of the input and waveforms together for the report. (Or for more fun, use a third probe to observe v_x as well. Save a screen-shot of all three waveforms together.)
- Finally, swap the order of the amps – amp 2 will be connected to the source and amp 1 will be the output. (You should be able to do this by swapping a couple of jumper wires — you shouldn't need to re-build the entire circuit.) Measure the total gain, which we might now label G_{21} , again. Is it different from the original configuration? Observe the waveforms on the oscilloscope.

6. Design it (optional)

This section is optional. It is fun and instructive, but do it only if you have time at the end of the lab period.

Design a non-inverting amplifier that has a gain of 11 ($\pm 5\%$). Include a “volume control” at the input in the form of an adjustable voltage divider made with a 10-k Ω potentiometer.

Build the circuit using the LM324 op amp with $\pm 10\text{-V}$ power supplies. With the volume control set near the mid-point (i.e. voltage divider ratio is about 1/2), apply a sinusoidal signal at the input. (Try starting with an amplitude of $0.5 V_{\text{RMS}}$ and a frequency of 1 kHz. Then, you can make adjustments as you work with your circuit.) Check the output on the oscilloscope to make certain that it is not clipping. Measure the RMS output voltage. Measure the RMS voltage at the *non-inverting terminal*. (Note, do not measure the function generator voltage – measure the voltage after the divider.) Calculate the gain and compare it to the expected value.

If you have time and interest, extend your design to make it into a stereo headphone amp. Start by building a second version of the non-inverting amp. Then use the 1/8” stereo-to-bread adapters available in the lab to connect the input to your phone audio output and the amplifiers outputs to your headphones.

BE CAREFUL! Check your wiring carefully, In particular, check the DC voltages at the inputs of the amplifier before you connect your phone. Large DC voltages can damage the audio output circuitry of your phone. The volume-control potentiometer should provide some protection, but check anyway. If you don’t want to use your phone, you can use the function generator to create some tones. The same comments apply when connecting your headphones at the output – a large DC voltage can quickly burn out the coil inside the headphone. Finally, keep voltage levels / volumes low at the start. If the amps are working properly, the sound will be much louder than what you are used to. Start low and keep the ear buds out of your ears initially, then work your way to higher volumes.

Report

Prepare a report describing your work and results. If you did the optional work of part 6, include a description of that, as well. Note the due dates for report on the class web site or by consulting the assignment listing on Canvas.